

CANdrive™

CANbus SAE J1939 to Electric Gauge Interface

00-02-0618
revision F, 7th January 2011
section 78



Installation and Operating Instructions

Please read the following information before installing. A visual inspection of this product for damage during shipping is recommended before installation. It is your responsibility to ensure that qualified mechanical and electrical technicians install this product. If in doubt, please contact your local Murphy representative.

General Information

⚠ **WARNING** ⚠

BEFORE BEGINNING INSTALLATION OF THIS PRODUCT

- ✓ Disconnect all electrical power to the machine
- ✓ Make sure the machine cannot operate during installation
- ✓ Follow all safety warnings of the machine manufacturer
- ✓ Read and follow all installation instructions

As part of the MurphyLink® family, CANdrive offers a cost effective instrument solution for modern electronic engines. CANdrive modules read engine ECU CANbus/J1939 data, drive standard electric panel gauges, and provide LED indication of status and faults.

CANdrive has three dedicated outputs for tachometer, oil pressure and coolant temperature gauges, with DIP switch-selectable compatibility for Murphy, VDO or Datcon gauges. For volume orders, the outputs can be custom-configured for other gauge types, lamps, relays or remote signalling.

CANdrive advantages include:

- the retrofitting of existing electric gauge panels to new, J1939 compatible engines
- the use of standard, economical electric gauges with new J1939 engines
- no need for installation of additional gauge senders, tachometer magnetic pickups and wiring.

CANdrive is packaged in a compact, surface mounted case with epoxy encapsulation for maximum durability and environmental sealing. Electrical connection is via a 12-way automotive type connector. Model CDV100F has a forward facing connector and one power/CAN status LED. Model CDV300R has 8 LEDs for indication of J1939-transmitted engine faults and status. All models include a 6-way DIP switch for flexible configuration.

Standard models & accessories

| Stock code | Description | Stock code | Description |
|------------|--|------------|---|
| 79.70.0001 | CDV100F, CANdrive™ J1939 to gauge interface, 1 x CAN status LED, connector forward | 79.70.1003 | CDVG, optional sealing gasket for CDV300R |
| 79.70.0002 | CDV300R, CANdrive™ J1939 to gauge interface, 8 x status/fault LEDs, connector rearward | 78.70.0363 | CDV100F plus CDV-PW-30 harness |
| 78.00.0437 | CDV-PW-30, 8 way wiring harness, length 30 in./760mm | 78.70.0364 | CDV300R, CDV-PW-30 and CDVG gasket |
| | | 79.70.1001 | CANdrive connector plug shell |
| | | 79.70.1002 | Connector pins for above (pack of 50) |



Patent applied for GB2424280

Specifications

Power supply

Operating voltage,
12V range (switch S5 on/up): 7 to 16 VDC
24V range (switch S5 off/down): 19 to 30 VDC

Current consumption:

CDV100: 25 mA typ.
CDV300: 50 mA typ. (2 LEDs lit)

Inputs

CANbus: SAE J1939 protocol. Input has a 120 Ohm terminating resistor, removable by switch S4.

Outputs (all ratings non-reactive)

Oil pressure gauge, engine temperature gauge:
switch selectable for Murphy, VDO or Datcon gauges:
see Gauge Compatibility section for pressure/temperature verses equivalent sender resistance tables

Tachometer: pulsed DC, 119 Hz ±1% @ 1500 RPM

Physical

Electromagnetic compatibility: 2004/108/EC

Case material: polycarbonate / polyester / epoxy encapsulation

Overall dimensions (w x h x d):

68 x 92 x 22mm / 2.7 x 3.7 x 0.9 in.
(allow 50mm / 2.0 in. depth with connector)

Weight: approx 80g / 0.2 lb

Temperature:

operation: -40 to +85°C / -40 to +185°F, 70% RH
storage: -55 to +105°C / -67 to +221°F

Environmental sealing: IP60

(CDV300R: IP65 from front with optional CDVG gasket)

Vibration: 15g, 10 to 2000 Hz, 3-axis

Shock: 50g, 11 mS, 3-axis

General Information (cont.)

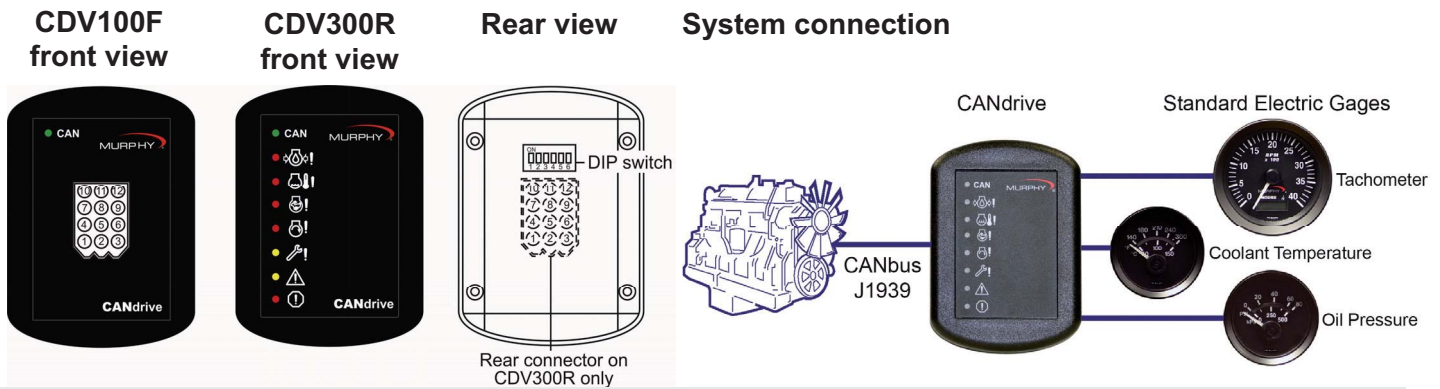

Panel Installation

CANdrive modules are surface-mounted with 4 x no.4 screws, fixing centre dimensions as shown. Select screw length according to panel thickness, ensuring a maximum of 13mm (½ inch) screw depth into the CANdrive fixing holes.

Model CDV100F, with forward facing connector, is designed for surface mounting inside an enclosed panel. Model CDV300F, with 8 LED indicators and rearward facing connector, is designed for front-of-panel mounting: this module requires an additional 60 x 40mm (2.4 x 1.6 in.) panel cut-out for rear access to connector and switches. A CDV300F with optional gasket CDVG (fitted into a well behind the case rim) provides IP65 front-of-panel environmental sealing.

Before installing, ensure that the final mounting location meets operating temperature and environmental sealing requirements, and allows access for:

- connection of the wiring harness
- configuration of DIP switches S1 to S5 (location as shown above right). Alternatively, set these switches before panel fixing – see Configuration section below for full details.

Dimensions

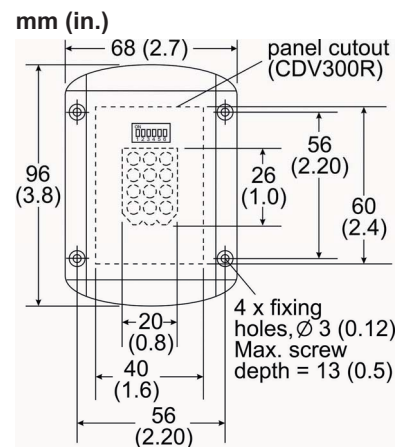

Configuration

DIP switches S1 to S5 allow OEM- or user-configuration of CANdrive operating options. Switch S6 is not used. CANdrive is supplied with all switches in the ON (up) position.

Switch settings must be made as appropriate, according to the configuration table right. Adjustment of the switch positions must be made while CANdrive is powered down.

| Switch position | ▲ on (up) | ▼ off (down) | Options: | | |
|-----------------|-----------|--------------|----------|----|---|
| S1 | S2 | S3 | S4 | S5 | |
| ▲ | ▲ | ▲ | | | Murphy temp. and pressure gauge <input type="checkbox"/> |
| ▼ | ▲ | ▲ | | | Datcon temp. and 0 – 7 bar pressure gauges |
| ▼ | ▲ | ▼ | | | <input type="checkbox"/> atcon temp. and 0 – 10 bar pressure gauges |
| ▲ | ▼ | ▲ | | | VDO temp. and 0 – 5 bar pressure gauges |
| ▲ | ▼ | ▼ | | | VDO temp. and 0 – 10 bar pressure gauges |
| | | | ▲ | | CAN 120 Ohm terminating resistor in circuit |
| | | | ▼ | | CAN 120 Ohm terminating resistor removed |
| | | | | ▲ | 12V DC <input type="checkbox"/> ower supply |
| | | | | ▼ | 24V DC power supply |

Pressure gauge compatibility table: pressure versus approximate equivalent sender resistance (Ohms)

| Pressure | psi | 0 | 10 | 20 | 30 | 40 | 50 | 60 | 70 | 80 | 90 | 100 | 110 | 120 | 130 | 140 |
|-------------------|-----|-----|-----|-----|-----|-----|-----|-----|-----|-----|-----|-----|-----|-----|-----|-----|
| | bar | 0 | 0.7 | 1.4 | 2.1 | 2.8 | 3.4 | 4.1 | 4.8 | 5.5 | 6.2 | 6.9 | 7.6 | 8.3 | 9.0 | 9.7 |
| Murphy | | 240 | 205 | 171 | 143 | 123 | 103 | 88 | 74 | 60 | 47 | 33 | | | | |
| Datcon 0 – 7 bar | | 240 | 195 | 160 | 140 | 115 | 100 | 82 | 68 | 55 | 43 | 35 | | | | |
| Datcon 0 – 10 bar | | 240 | 215 | 190 | 168 | 150 | 135 | 118 | 107 | 97 | 87 | 77 | 67 | 58 | 50 | 42 |
| VDO 0 – 5 bar | | 10 | 38 | 61 | 85 | 110 | 130 | 155 | 180 | | | | | | | |
| VDO 0 – 10 bar | | 15 | 30 | 45 | 60 | 70 | 81 | 92 | 103 | 114 | 125 | 136 | 148 | 160 | 170 | 182 |

Temperature gauge compatibility table: temperature versus approximate equivalent sender resistance (Ohms)

| Temperature | °C | 40 | 50 | 60 | 70 | 80 | 90 | 100 | 110 | 120 | 130 | 140 |
|-------------|----|-------|-------|-------|------|------|------|------|------|------|------|------|
| | °F | 104 | 122 | 140 | 158 | 176 | 194 | 212 | 230 | 248 | 266 | 284 |
| Murphy | | 1029 | 680 | 460 | 321 | 227 | 164 | 120 | 89 | 74 | 52 | 40 |
| Datcon | | 360 | | 160 | | 80 | | 50 | | 38 | | |
| VDO | | 282.4 | 190.0 | 134.0 | 95.2 | 69.1 | 51.2 | 38.5 | 29.4 | 22.7 | 18.0 | 14.5 |

Electrical Connection

CANdrive electrical connection is via a 12-way automotive type receptacle shown right. CANdrive models are available with the connector facing forward through the front label ('F' option, e.g. model CDV100F), or rearward through the epoxy encapsulation ('R' option, e.g. model CDV300R).

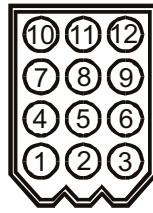

An 8-way, 30"/270mm wiring harness is available as an additional loose item or as part of a CANdrive kit. For customer-made harnesses, part numbers for the mating connector plug and pins are as follows:

| | Murphy part ref. | Molex part ref. |
|--|------------------|--------------------------|
| Connector plug shell x 1 (1 required per unit) | 79.70.1001 | 03-09-1125 or 03-09-1126 |
| Connector pins, pack of 50 (max 8 required per unit) | 79.70.1002 | 02-09-1104 |

Terminal functions

Pin Function

- 1 Negative DC, power supply
- 2 Positive DC, power supply
- 3 Negative DC, gauge common return

CANdrive is supplied for use with 12V (7 to 16V) DC operation. If 24V (19 to 30V) DC operation is required, push DIP switch S5 to the off (down) position.

Connect a 1 Amp anti-surge fuse in the positive DC line (pin 2).

Pins 1 and 3 are internally linked: pin 1 is typically used as a power supply connection; pin 3 is typically used as a common negative return for the gauge outputs.

- 4 Oil pressure gauge output
- 6 Coolant temperature gauge output
- 7 Tachometer output

Pins 4 and 6 give a variable current output for driving oil pressure and coolant temperature electric gauges. The current output versus pressure/temperature is specific to each gauge type, as selected using DIP switches S1, S2 and S3 – see Configuration section.

Pin Function

Pin 7 gives a square wave output (0V to battery positive DC), with a frequency proportional to engine speed. At 1500 RPM engine speed, the output frequency is 119 Hz ($\pm 1\%$), suitable for driving charge alternator based tachometers such as the Murphy ATA and ATHA series. Pin 7 gives no output when engine speed is below 100 RPM.

Connect each output to the appropriate gauge/tachometer signal input. Connect gauge/tachometer negative terminals to battery negative, ideally via dedicated wiring to terminal 3. (The use of dedicated return wiring to pin 3, rather than a ground/earth return, minimises gauge inaccuracies caused by ground noise.)

- 5 CAN Hi
- 8 CAN Lo

Connect these terminals to the engine CANbus, taking care to observe the correct polarity. The CANbus cable shield/screen is typically connected to ground/earth at one end only (often at the ECU): refer to the engine manufacturer's installation guidelines.

CANbus J1939 specifications require two 120 Ohm terminating resistors at each end of the network. CANdrive is supplied with a 120 Ohm network terminating resistor in circuit. If CANdrive is not positioned at the end of the CANbus network, switch out the terminating resistor by pushing DIP switch S4 off (down) – see Configuration section for details.

- 9 Reserved for future use
- 10 Factory use
- 11 Factory use
- 12 Factory use

These connections are reserved for future use, or are used in the factory setup of CANdrive. Do not connect wiring or equipment to these terminals: connection may result in permanent damage to CANdrive.

Typical Connection

Shown with Murphy EG(S) series gauges/Swichgages and AT(H)A tachometer.

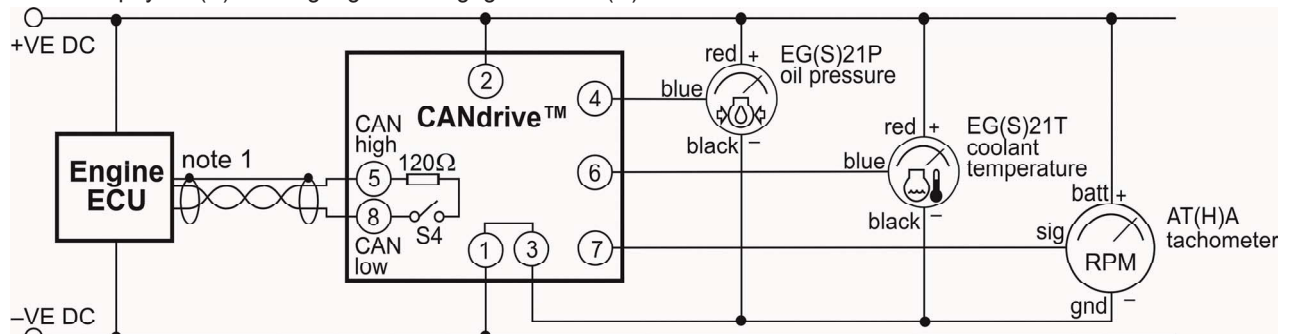

Notes: 1) CANbus J1939 networks typically have two 120 Ohm terminating resistors (one at each end), with a shield/screen connected to ground/earth at one end only. Check engine & ECU documentation for details.

Operation and Maintenance

Operation

Gauge driver outputs







The gauge outputs operate when CANdrive reads valid J1939 data for engine speed, oil pressure and coolant temperature. If CANdrive stops receiving valid data, the gauge outputs are maintained at the last known value for approximately 5 seconds, after which time the outputs turn off.

Indicating LEDs

All standard models have a green CAN LED. A flashing CAN LED indicates that CANdrive is powered, but is not receiving any J1939 data. A constantly lit CAN LED indicates power on with good CANbus connection and J1939 activity. (Note: J1939 activity can originate from ANY device on the CANbus network, and may not necessarily be valid data from the engine ECU.)

Model CDV300R has additional LEDs for indication of J1939-transmitted engine faults. CANdrive responds to single DM1 (active fault code) messages that contain SPN (Suspect Parameter Number), FMI (Fault Mode Indicator) and warning/stop lamp data. CANdrive also reads multi-packet transport messages broadcast using the BAM protocol.

Typically, LEDs light continuously to indicate a shutdown fault, and flash to indicate a (non-shutdown) warning fault:

| LED | Mode | Fault | J1939 | |
|---|----------|------------------------------|-------|-----|
| | | | SPN | FMI |
|  | On | Low oil pressure shutdown | 100 | 1 |
| | Flashing | Low oil pressure warning | 100 | > 1 |
|  | On | Coolant temperature shutdown | 110 | 0 |
| | Flashing | Coolant temperature warning | 110 | > 0 |
|  | On | Overspeed shutdown | 190 | 0 |
| | Flashing | Overspeed warning | 190 | > 0 |
|  | - | Reserved for future use | - | - |
|  | - | Reserved for future use | - | - |
|  | Flashing | Warning fault | - | - |
|  | Flashing | Shutdown fault | - | - |

CANdrive can handle up to 8 simultaneous faults at one time: additional fault messages are not registered. When a fault becomes inactive and is no longer broadcast, the appropriate LED goes out after approximately 2 seconds.

FW MURPHY
P.O. Box 470248, Tulsa, Oklahoma 74147 USA
+1 918 317 4100 Fax: +1 918 317 4266
E-mail: sales@fwmurphy.com

INDUSTRIAL PANEL DIVISION
Fax: +1 918 317 4124
E-mail: ipdsales@fwmurphy.com

MURPHY POWER IGNITION
Website: www.murphy-pi.com

CONTROL SYSTEMS AND SERVICES DIVISION
P.O. Box 1819, Rosenberg, Texas 77471 USA
Phone: +1 281 633 4500 Fax: +1 281 633 4588
E-mail: css-solutions@fwmurphy.com

FRANK W. MURPHY LTD.
Church Road, Laverstock,
Salisbury, SP1 1GZ, United Kingdom
Tel: +44 1722 410055
Fax: +44 1722 410088
E-mail: sales@fwmurphy.co.uk
Web: www.fwmurphy.co.uk

COMPUTRONIC CONTROLS
41 - 46 Railway Terrace, Nechells,
Birmingham, B7 5NG, United Kingdom
E-mail: sales@computroniccontrols.com
Web: www.computroniccontrols.com

FW MURPHY INSTRUMENTS (HANGZHOU) CO., LTD.
77 23rd Street, Hangzhou Economic & Technological Development Area
Hangzhou, Zhejiang, 310018, China
Phone: +86 571 8788 6060 Fax: +86 571 8684 8878
E-mail: apsales@fwmurphy.com



USA-ISO 9001:2008 FM 28221
UK-ISO 9001:2008 FM 29422
Registered Facilities

ISO 9001
REGISTERED

Maintenance and Warranty

CANdrive has no user-serviceable parts. Maintenance is therefore limited to the following preventative checks:

- Check that electrical connections are secure.
- Check that the CANdrive is securely mounted, and kept free from ingress of water or build up of excessive dust/dirt. The front label and casing may be wiped with a clean, damp cloth. Do not use cleaning solvents.

CANdrive is supplied with a 2 year warranty on parts and workmanship. In the event of a fault or technical query, please contact your Murphy representative for technical support.

Further information

Document Description

00-02-0251 EG(S)21 series electric gage installation

00-02-0258 AT series tachometer installation