

Keystart 9620/9621

Engine & Generator Controls

00-02-0657
revision C, 29th January 2010
section 40 & 75



Installation Instructions

Please read the following information before installing. A visual inspection of this product for damage during shipping is recommended before installation. It is your responsibility to ensure that qualified mechanical and electrical technicians install this product. If in doubt, please contact your local Murphy representative.

General Information

WARNING

BEFORE BEGINNING INSTALLATION OF THIS PRODUCT

- ✓ Disconnect all electrical power to the machine
- ✓ Make sure the machine cannot operate during installation
- ✓ Follow all safety warnings of the machine manufacturer
- ✓ Read and follow all installation instructions

General

The Keystart 9620 and 9621 modules provide manual start/stop and automatic fault shutdown protection for generators, pumps and other engine-driven applications.

Keystart features a 4 way keyswitch for operator control of the engine, with 6 LEDs for indication of status and faults - see 'front view' diagram for details. Electrical connection and configuration options are at the rear - see 'Rear view, connection and settings' diagram.

For each Keystart ordered, the following is supplied:

- 1 x Keystart module, fitted with 4 x panel mounting clips
- 2 x keys
- these instructions

Panel installation

Keystart is designed for front-of-panel mounting in a DIN standard 92 x 92 mm (3.6 x 3.6 in.) cut-out. Allow 75mm (3.0 in.) behind the panel for the case depth, keyswitch and cable connection.

Secure the case to the panel with the two ratcheted mounting clips:

1. Remove the 4 plastic mounting clips from the Keystart case: release each clip's ratchet mechanism by pulling outwards (A), then slide the clip back and off the case (B).
2. At the front of the panel, insert the Keystart (without clips) into the panel cut-out (C).
3. At the rear of the panel, refit the two mounting clips into the slots on the Keystart case (D). Slide each clip forward until the arms (E) are secured behind the panel face. Ratchet mechanism (F) prevents the clip from moving backwards.



Specifications

Power supply

Operating voltage, steady state: 7 to 30 VDC
Operating voltage, brown out / cranking: 5 VDC minimum
Current consumption: < 100mA

Inputs

Fault switch inputs: close to negative DC during fault

Generator AC input (model 9621 only):

70 – 270 VAC rms, <50 to >60 Hz nominal

Magnetic pickup input (model 9621 only):

3.5 – 21 VAC rms, <2000 to >6500 Hz nominal

Outputs (all ratings non-reactive)

Run (fuel): positive DC, NO relay contacts, 10A max @ 24VDC

Start (crank): positive DC, keyswitch contacts, 10A max @ 24VDC

Alarm: negative DC (open collector transistor), 300mA max

Speed calibration: to suit 0 – 1mA, 75 Ohm meter,
output = 0.75mA at rated engine speed

Adjustable settings

Preheat timer: 0 or 10 secs (links J1 and J4), default = 0 secs

Fault override timer: 2 to 20 secs (VR1), default = 10 secs

Overspeed trip level (model 9621 only): 100 to 130% (VR3) of
nominal calibrated speed, default = 110% (of 50 or 60 Hz)

Physical

Case material: polycarbonate / polyester

Overall dimensions (w x h x d): 96 x 96x 95mm / 3.8 x 3.8 x 3.7 in.

Panel cut-out size: DIN 92 x 92mm / 3.6 x 3.6 in.

Weight: approx 300g / 0.7 lb

Operating temperature: –35 to +55 °C / –31 to +131 °F

Model options

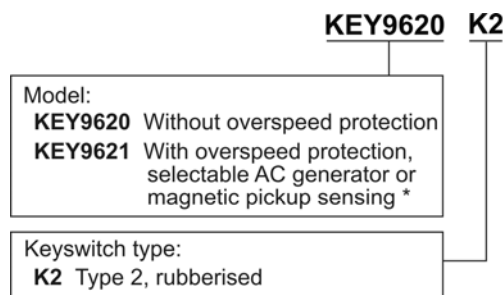

* factory default setting is for AC generator sensing, calibrated to either 50 or 60 Hz nominal. Non-standard (NS) settings/options are available to order.

General Information (cont.)

Front view and operation

LED indication:-

run (fuel) on - green	preheat on - amber
low oil pressure fault shutdown - red	high engine temperature fault shutdown - red
overspeed/aux 2 fault shutdown - red	charge fail warning - red
aux 1 fault shutdown - red	



4 position keyswitch:

- **Off/Reset.** Removes power, stops the engine and resets any latched shutdown fault.
- | **Run.** Activates the Run output and (if enabled) the timed Preheat output. Once the engine is fully running, and after the 'override' time, Keystart immediately shuts down the engine on detection of a fault.
- || **Start/crank.** Maintains the Run output, and activates the Start (crank) output. Shutdown fault inputs are disabled and the fault override timer is reset. This position spring-returns to I (Run) on release.
- ||| **Auxiliary.** Keyswitch auxiliary output, positive DC.

Rear view, connections and settings

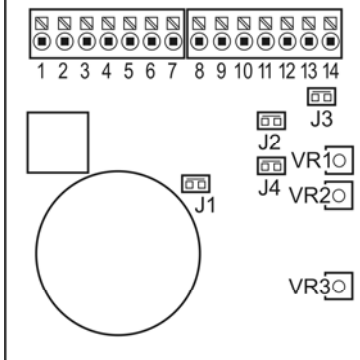

Connection:-

- 1 run (fuel) output: +DC, 10A
- 2 preheat output: +DC, 10A
- 3 start (crank) output: +DC, 10A
- 4 + DC power supply
- 5 charge fail (WL)
- 6 oil pressure fault input
- 7 aux. 1 fault input
- 8 engine temp fault input
- 9 aux. 2 fault input
- 10 alarm output: -DC, 250mA
- 11 speed calibration output
- 12 - DC power supply

Speed input, model 9621 only:
links J2 and J3 ON:
 13 L } Generator AC, 50/60Hz
 14 N } 70-270 VAC, 50/60Hz
links J2 and J3 OFF:
 13 + } magnetic pickup,
 14 - } 3.5-21 VAC, 2000-6500Hz

Configuration:-
Use a 3 mm/0.1 in. flat head screwdriver for potentiometers VR1-VR3

All models:-
J1 & J4: preheat output timing
 - J1 ON: no preheat
 - J1 OFF, J4 OFF: preheat 10 secs fixed, unaffected by crank
 - J1 OFF, J4 ON: preheat 10 second max, cancelled by crank
VR1: Fault override, 2 - 20 secs, clockwise to increase.

Model 9621 only:-
J2 & J3: speed sensing source (pins 13 and 14):-
 - both links ON for generator AC, 50/60Hz
 - both links OFF for magnetic pickup, 2000 - 6500 Hz.
VR2: Speed calibration. Set J2 and J3 correctly, run engine to nominal speed, adjust VR2 to give (pin 11) calibration output of 0.75mA
VR3: Overspeed, 100 - 130% of VR2 setting, clockwise to increase

Electrical Connection



DANGER ! HIGH VOLTS

WARNING: DANGER OF INJURY OR DEATH. Keystart 9621 controllers allow connection of high voltage AC circuits. Before connection, disconnection or handling of these units, ensure that all AC and DC power supplies are isolated. Connection to or disconnection from live wiring may also cause damage to the Keystart's internal components.

Electrical connection to 0.5 to 1.5 mm² / 16 – 20 AWG panel wiring is by spring-clamp terminals at the rear.

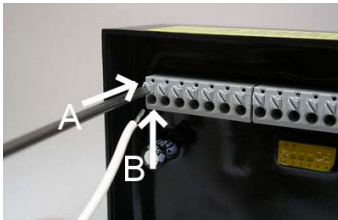

- pre-strip 8 to 10 mm / 0.3 to 0.4 in. of insulation from each wire.
- Above each terminal is a square push-button with a diagonal slot. Insert a flat-head screwdriver into the slot (A), then push down to (towards the front of the Keystart) to open the terminal clamp.
- insert the wire into the terminal (B), checking that the insulation is clear of the clamp. Release the screwdriver/spring clamp pressure and check that the wire is secure.

General connection recommendations

Murphy make several recommendations for the electrical connection of engine and generator controllers.

- minimise controller output load current (i.e. wear/tear and potential damage) by using slave relays between the controller outputs and high power end-devices such as fuel and starter solenoids.
- Suppress (at source) electrical interference from panel relay and engine solenoid coils, using flywheel diode or proprietary snubber networks as appropriate.

- use separate routing for AC and DC wiring harnesses.
- use separate wiring for a) connection of battery charger to battery, and b) connection of battery to panel DC supply. Separate wiring will reduce high frequency battery charger output noise on the panel DC power supply.

Terminal functions

Pin	Function
1	Run (fuel) output
2	Preheat output

These relay outputs provide control for a the engine's preheater and (energised to run) fuel / ignition circuits.

The Run output (pin 1) gives a positive DC signal (operating engine fuel) immediately on switching the key to the I (RUN) position. The Run output remains active, and the green LED lights, until the operator switches the key to O (STOP) or until the Keystart initiates an automatic fault shutdown.

When preheat configuration link J1 is fitted (the default setting), the Preheat timer and output (pin 2) do not operate. If link J1 is removed, the preheat output gives a positive DC signal on switching the key to the I (RUN) position. If link J4 is fitted, the preheat timer and output immediately de-activate when the key is switched to II (start/crank); if J4 is removed, the 10 sec preheat continues regardless of cranking. The amber LED lights while the Preheat output is active.

Both Run and Preheat outputs are rated 10 Amp max. @ 24VDC. Murphy recommend the connection of slave relays with suppressed coils between these outputs and fuel solenoid coil and engine preheaters - see 'typical connection' diagram below.

Electrical Connection (cont.)

Terminal functions (cont.)

Pin Function

3 Start (crank) output
Pin 3 gives a positive DC, 16 Amp rated output when the key is switched to position **II** (start/crank). To prolong keyswitch contact life, connect a slave relay (with suppressed coil) between pin 3 and the engine starter solenoid coil - see 'typical connection' diagram below.

4 Power Supply, Positive DC
12 Power Supply, Negative DC
The Keystart operates with any smooth DC / battery voltage in the range 7 – 30V. Supply brown-out protection is fitted as standard. Connect a 5 Amp anti-surge fuse in the positive DC line (pin 4).

5 Charge fail
The charge fail LED lights, but there is no shutdown or alarm, when pin 5 is connected to battery negative. When using a charge alternator, connect pin 5 to the alternator warning lamp (WL) terminal. (Note: pin 5 supplies the alternator excitation current).

6 Low Oil Pressure (LOP) fault input
7 Auxiliary 1 fault input
8 High Engine Temperature (HET) fault input
9 Auxiliary 2 fault input
Use remote switch or relay contacts that connect these inputs to battery negative during fault conditions. The Keystart shuts down the engine, lights the appropriate fault LED, and activates the alarm output. Note: activation of pin 9 (Aux 2 input) causes engine shutdown and illumination of the overspeed LED.

For all the above inputs, shutdown is inhibited during engine cranking and until the end of the fault 'override' time (adjustable 2 – 20 secs using potentiometer VR1, clockwise to increase). To reset a shutdown fault condition, turn the key to **O** (Off) or remove the DC power supply.

10 Alarm output
Pin 10 is a semiconductor-based (open collector NPN transistor) output that gives a negative DC output immediately after a fault shutdown. Output rating is 250mA max.: the output typically drives an audible/visible alarm circuit, using a slave relay with suppressed coil - see 'typical connection' opposite.

11 Speed calibration (& indication) output
This output is designed to work with a 0 - 1 mA DC ammeter, either a) during set-up to aid speed calibration (and overspeed fault protection), or b) in normal operation to indicate engine speed or generator Hz.

For calibration, connect meter positive to pin 11 and meter negative to battery negative, e.g. at terminal 12. See 'speed sensing and calibration' below for setup procedure.

For indication of engine RPM or generator Hz, the 0 – 1mA DC ammeter must be fitted with a custom scale. The speed calibration output current is proportional to the speed input frequency. When correctly calibrated using VR2, Keystart gives 0 mA at 0 RPM/Hz. and 0.75mA (3/4 scale) at normal running RPM/Hz.

Pin Function

With links J2 & J3 ON:
13 Generator AC Live
14 Generator AC Neutral



When configuration links J2 and J3 are fitted (the default factory setting), terminals 13 and 14 are configured for speed sensing using a high voltage, generator AC 50/60Hz. signal.

The input accepts generator AC voltages between 70 and 270 VAC rms. A 1 Amp anti-surge fuse should be connected in series with AC live (pin 13). See 'speed sensing' below for correct calibration of this input using potentiometers VR2 and VR3.

To configure this input for magnetic pickup engine speed sensing, see section below.

With links J2 & J3 OFF:
13 Magnetic pickup signal input
14 Magnetic pickup return

When configuration links J2 and J3 are removed, terminals 13 and 14 are configured for speed sensing by a magnetic pickup and flywheel/gearwheel combination.

Connect the magnetic pickup to the input using two-core and screen cable. To minimise electrical interference on the speed signal, connect the cable screen to earth at one end only.

Magnetic pickup signal requirements are 3.5 to 21 VAC rms, with frequency between 2000 and 6500 Hz. when the engine is running at nominal speed. See 'speed sensing' below for correct calibration of this input using potentiometers VR2 and VR3.

To configure this input for generator AC frequency sensing, see section above.

Typical connection

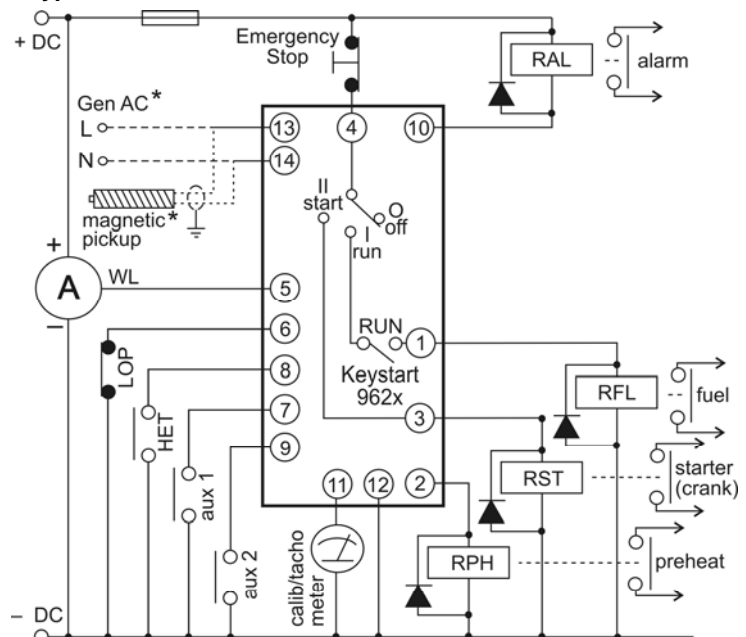

Notes:-

* Overspeed models 9621 only. Select generator AC or magnetic pickup speed sensing using links J2 & J3 (see rear view diagram). Factory default setting is for generator AC sensing.

Speed Sensing and Calibration

Keystart model 9621 includes a speed sensing input and automatic shutdown protection for engine overspeed faults. Before use, model 9621's speed input must be correctly configured (using circuit-board links J2 and J3) and calibrated (using potentiometers VR2 and VR3).

Selection of speed signal source: links J2 and J3

Links J2 and J3 allow configuration of the speed sensing input (terminals 13 and 14) for either high voltage generator AC (the factory default setting) or magnetic pickup signals. Use small pliers to add or remove the links as required:

J2 and J3 links	Terminal 13 and 14 configuration
ON	Generator AC, 70 - 270 VAC rms, 50 or 60 Hz nominal.
OFF	Magnetic pickup, 3.5 – 21 VAC rms, 2000 to 6500 Hz nominal.

Speed calibration

Speed calibration is a two stage process:

1) Nominal speed calibration: potentiometer VR2

The factory default setting is for generator AC speed sensing, with standard models for either 50 or 60Hz nominal calibration. To recalibrate for other systems:

- Select the speed sensing method (generator AC or magnetic pickup) using links J2 and J3 as detailed above.
- Turn VR2 fully clockwise (sets calibration for maximum nominal frequency).
- Connect a 0 – 1mA, 75 Ohm meter between pin 11 and battery negative, as detailed in 'electrical connection' above.
- Start and run the engine to nominal (normal running) speed.
- Turn VR2 anti-clockwise (decreasing the calibration frequency) until the ammeter rises to read 0.75mA.

2) Overspeed setting: potentiometer VR3

VR3 allows adjustment of the overspeed trip point, between approximately 100 and 130% of the nominal speed calibration level (as set using VR2). The VR3 factory default setting is 110% (of either 50 or 60Hz). To adjust the overspeed trip level:

- Turn VR3 fully clockwise (to maximum, approx. 130% of nominal)
- Start and run the engine. Increase engine speed to the required overspeed/over-frequency trip level.
- Turn VR3 slowly anti-clockwise (decreasing the overspeed trip level) until the Keystart shuts down the engine and indicates 'overspeed'.

Where the engine speed cannot be adjusted, or if the speed signal cannot be simulated (e.g. with an adjustable signal generator), an approximate overspeed setting must be made, e.g. potentiometer mid-span = approximately 115% of VR2 nominal.

Maintenance and Warranty

The Keystart contains the following replaceable parts:-

Document	Description
41.70.0157	Spare mounting clips (pack of 4)
76.70.0127	Spare keyswitch (K1 type), inc. key
65.70.0256	Spare keyswitch (K2 type), inc. key
00.00.3235	Spare key (K2 type)

The Keystart series contains no other user-serviceable parts.

Maintenance is therefore limited to the following preventative checks:

- Check that all electrical connections are secure.
- Check that configuration links J1 - J4 are fitted correctly.
- Check that the Keystart is securely clamped in the front of panel aperture, and kept free from ingress of water or build up of excessive dust or dirt. The front face label and casing may be wiped with a clean, damp cloth. Do not use cleaning solvents.

Each Keystart is supplied with a two year warranty on materials and workmanship. In the event of a fault or technical query, please contact your Murphy representative for technical support.

In order to consistently bring you the highest quality, full featured products, we reserve the right to change our specifications and designs at any time. MURPHY, the Murphy logo, are registered and/or common law trademarks of Murphy Industries, Inc. This document, including textual matter and illustrations, is copyright protected by Frank W Murphy Ltd., with all rights reserved. © 2010 Frank W Murphy Ltd.

FW MURPHY

P.O. Box 470248, Tulsa, Oklahoma 74147 USA
+1 918 317 4100 Fax: +1 918 317 4266
E-mail: sales@fwmurphy.com

INDUSTRIAL PANEL DIVISION

Fax: +1 918 317 4124
E-mail: ipdsales@fwmurphy.com

MURPHY POWER IGNITION

Website: www.murphy-pi.com

CONTROL SYSTEMS AND SERVICES DIVISION

P.O. Box 1819, Rosenberg, Texas 77471 USA
Phone: +1 281 633 4500 Fax: +1 281 633 4588
E-mail: css-solutions@fwmurphy.com

FRANK W. MURPHY LTD.

Church Road, Laverstock,
Salisbury, SP1 1QZ, United Kingdom
Tel: +44 1722 410055
Fax: +44 1722 410088
E-mail: sales@fwmurphy.co.uk
Web: www.fwmurphy.co.uk

COMPUTRONIC CONTROLS

41 - 46 Railway Terrace, Nechells,
Birmingham, B7 5NG, United Kingdom
Tel: +44 121 327 8500
Fax: +44 121 327 8501
E-mail: sales@computroniccontrols.com
Web: www.computroniccontrols.com

FW MURPHY INSTRUMENTS (HANGZHOU) CO., LTD.

77 23rd Street, Hangzhou Economic & Technological Development Area
Hangzhou, Zhejiang, 310018, China
Phone: +86 571 8788 6060 Fax: +86 571 8684 8878
E-mail: apsales@fwmurphy.com



USA-ISO 9001:2000 FM 28221
UK-ISO 9001:2000 FM 29422
Registered Facilities

ISO 9001
REGISTERED