

# CANdrive™

## CANbus J1939 to Electric Gauge Interface



Patent applied for GB2424280



### Features

- For modern electronic engines and equipment applications using SAE J1939 Controller Area Network
- Drives standard electric gauges
- User-configurable compatibility with Murphy, VDO or Datcon gauges
- Engine fault LED option

As part of the MurphyLink® family, CANdrive offers a cost effective instrument solution for modern electronic engines. CANdrive modules read engine ECU CANbus/J1939 data, drive standard electric panel gauges, and provide LED indication of status and faults.

CANdrive has three dedicated outputs for tachometer, oil pressure and coolant temperature gauges, with DIP switch-selectable compatibility for Murphy, VDO or Datcon gauges. For volume orders, the outputs can be custom-configured for other gauge types, lamps, relays or remote signalling.

CANdrive advantages include:

- the retrofitting of existing electric gauge panels to new, J1939 compatible engines
- the use of standard, economical electric gauges with new J1939 engines
- no need for installation of additional gauge senders, tachometer magnetic pickups and wiring.

CANdrive is packaged in a compact, surface mounted case with epoxy encapsulation for maximum durability and environmental sealing. Electrical connection is via a 12-way automotive type connector. Model CDV100F has a forward facing connector and one power/CAN status LED. Model CDV300R has 8 LEDs for indication of J1939-transmitted engine faults and status. All models include a 6-way DIP switch for flexible configuration.

### Specifications

#### Power supply

##### Operating voltage,

12V range (switch S5 on/up): 7 to 16 VDC

24V range (switch S5 off/down): 19 to 30 VDC

##### Current consumption:

CDV100: 25 mA typ.

CDV300: 50 mA typ. (2 LEDs lit)

#### Inputs

**CANbus:** SAE J1939 protocol. Input has a 120 Ohm terminating resistor, removable by switch S4.

#### Outputs (all ratings non-reactive)

##### Oil pressure gauge, engine temperature gauge:

switch selectable for Murphy, VDO or Datcon gauges:

see Gauge Compatibility section for pressure/temperature verses equivalent sender resistance tables

**Tachometer:** pulsed DC, 119 Hz  $\pm$ 1% @ 1500 RPM

#### Physical

**Electromagnetic compatibility:** 2004/108/EC

**Case material:** polycarbonate / polyester / epoxy encapsulation

**Overall dimensions (w x h x d):**

68 x 92 x 22mm / 2.7 x 3.8 x 0.9 in.

(allow 50mm / 2.0 in. depth with connector)

**Weight:** approx 80g / 0.2 lb

##### Temperature:

operation: -40 to +85°C / -40 to +185°F, 70% RH

storage: -55 to +105°C / -67 to +221°F

**Environmental sealing:** IP60

(CDV300R: IP65 from front with optional CDVG gasket)

**Vibration:** 15g, 10 to 2000 Hz, 3-axis

**Shock:** 50g, 11 mS, 3-axis

**Warranty** - A two year limited warranty on materials and workmanship is given with this FW Murphy product. A copy of the warranty may be viewed or printed by going to [www.fwmurphy.co.uk/warranty](http://www.fwmurphy.co.uk/warranty)

## CDV100F front    CDV300R front    Rear view and configuration

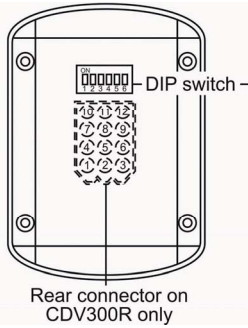

Switch position		▲ on (up)	▼ off (down)	Options:
S1	S2	S3	S4	S5
▲	▲	▲		Murphy temp. & pressure gauges
▼	▲	▲		Datcon temp. & 0 – 7 bar pressure gauges
▼	▲	▼		Datcon temp. & 0 – 10 bar pressure gauges
▲	▼	▲		VDO temp. & 0 – 5 bar pressure gauges
▲	▼	▼		VDO temp. & 0 – 10 bar pressure gauges
			▲	CAN 120 Ohm terminating resistor in circuit
			▼	CAN 120 Ohm terminating resistor removed
			▲	12V DC power supply
			▼	24V DC power supply

## Gauge compatibility

Pressure gauge compatibility table: pressure versus approximate equivalent sender resistance (Ohms)

Pressure	psi	0	10	20	30	40	50	60	70	80	90	100	110	120	130	140
	bar	0	0.7	1.4	2.1	2.8	3.4	4.1	4.8	5.5	6.2	6.9	7.6	8.3	9.0	9.7
Murphy		240	205	171	143	123	103	88	74	60	47	33				
Datcon 0 – 7 bar		240	195	160	140	115	100	82	68	55	43	35				
Datcon 0 – 10 bar		240	215	190	168	150	135	118	107	97	87	77	67	58	50	42
VDO 0 – 5 bar		10	38	61	85	110	130	155	180							
VDO 0 – 10 bar		15	30	45	60	70	81	92	103	114	125	136	148	160	170	182

Temperature gauge compatibility table: temperature versus approximate equivalent sender resistance (Ohms)

Temperature	°C	40	50	60	70	80	90	100	110	120	130	140
	°F	104	122	140	158	176	194	212	230	248	266	284
Murphy		1029	680	460	321	227	164	120	89	74	52	40
Datcon		360		160		80		50		38		
VDO		282.4	190.0	134.0	95.2	69.1	51.2	38.5	29.4	22.7	18.0	14.5

Tachometer compatibility: pulsed DC output, 119 Hz ±1% at 1500 RPM, e.g. for use with Murphy ATA and ATHA tachometers

## How to order

Stock code	Description
79.70.0001	CDV100F, CANdrive™ J1939 to gauge interface, 1 x CAN status LED, connector forward
79.70.0002	CDV300R, CANdrive™ J1939 to gauge interface, 8 x status/fault LEDs, connector rearward
78.00.0437	CDV-PW-30, 8 way wiring harness, length 30 in./760mm
79.70.1003	CDVG, optional sealing gasket for CDV300R
78.70.0363	CDV100F plus CDV-PW-30 harness
78.70.0364	CDV300R, CDV-PW-30 and CDVG gasket
79.70.1001	CANdrive connector plug shell
79.70.1002	Connector pins for above (pack of 50)

## Connection

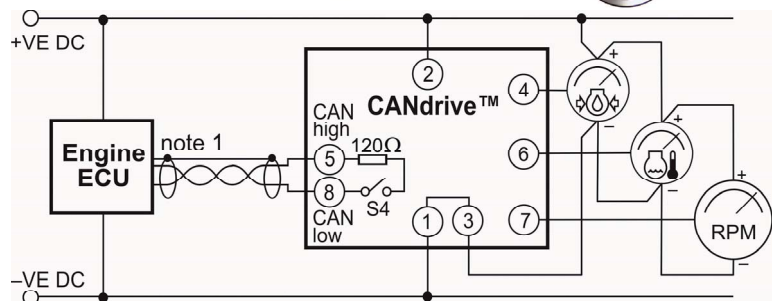

Notes: 1) CANbus J1939 networks typically have two 120 Ohm terminating resistors (one at each end), with a shield/screen connected to ground/earth at one end only. Check engine & ECU documentation for details.

## Further information

Document	Description
00-02-0618	CANdrive installation and operation
00-02-0251	EG(S)21 series electric gage installation
00-02-0258	AT series tachometer installation

**FW MURPHY**  
P.O. Box 470248, Tulsa, Oklahoma 74147 USA  
+1 918 317 4100 Fax: +1 918 317 4266  
E-mail: sales@fwmurphy.com

**INDUSTRIAL PANEL DIVISION**  
Fax: +1 918 317 4124  
E-mail: ipdsales@fwmurphy.com

**MURPHY POWER IGNITION**  
Website: www.murphy-pi.com

**CONTROL SYSTEMS AND SERVICES DIVISION**  
P.O. Box 1819, Rosenberg, Texas 77471 USA  
Phone: +1 281 633 4500 Fax: +1 281 633 4588  
E-mail: css-solutions@fwmurphy.com

**FRANK W. MURPHY LTD.**  
Church Road, Laverstock,  
Salisbury, SP1 1GZ, United Kingdom  
Tel: +44 1722 410055  
Fax: +44 1722 410088  
E-mail: sales@fwmurphy.co.uk  
Web: www.fwmurphy.co.uk

**COMPUTRONIC CONTROLS**  
41 – 46 Railway Terrace, Nechells,  
Birmingham, B7 5NG, United Kingdom  
E-mail: sales@computroniccontrols.com  
Web: www.computroniccontrols.com

**FW MURPHY INSTRUMENTS (HANGZHOU) CO., LTD.**  
77 23<sup>rd</sup> Street, Hangzhou Economic & Technological Development Area  
Hangzhou, Zhejiang, 310018, China  
Phone: +86 571 8788 6060 Fax: +86 571 8684 8878  
E-mail: apsales@fwmurphy.com



USA-ISO 9001:2008 FM 28221  
UK-ISO 9001:2008 FM 29422  
Registered Facilities

