

# Autostart 700 (model numbers AS3/E...) Engine/Generator Controller Installation Reference Sheet

mi5316  
revision B, 8<sup>th</sup> October 2001  
catalogue section 75



## Front Facia

4 position operating mode keyswitch:-  
Off/reset  
Lamp Test  
Auto  
Test (Manual)

7 status/fault LEDs

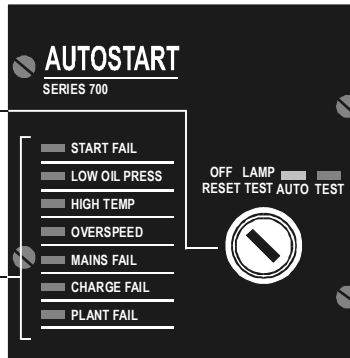

## Top Facia and Switch Settings

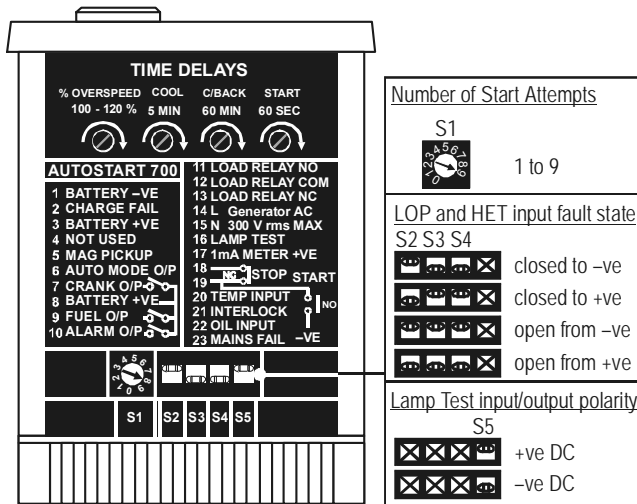

## Rear Facia and Electrical Connection

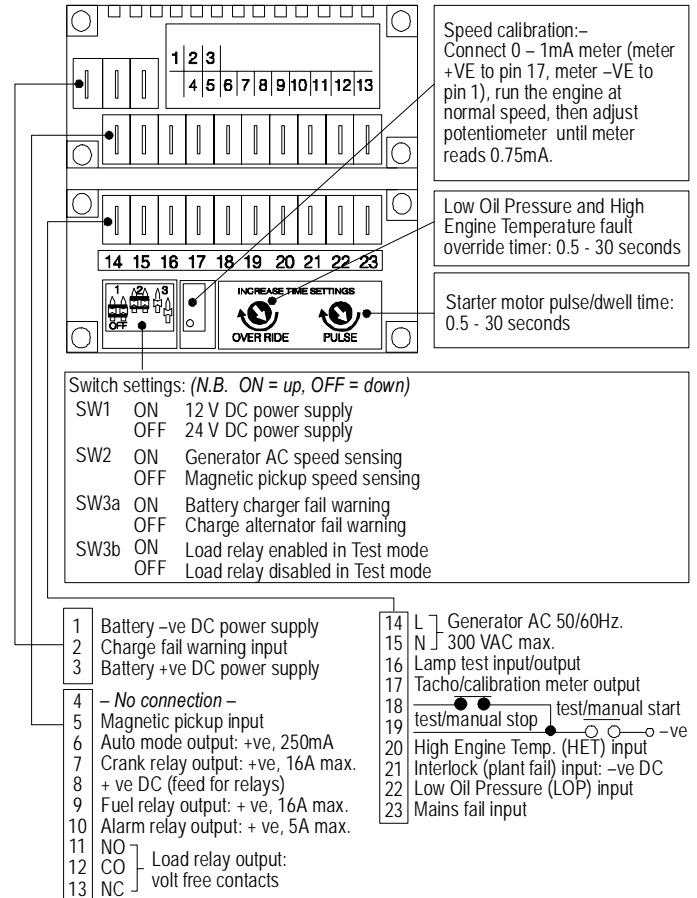

## Panel Installation

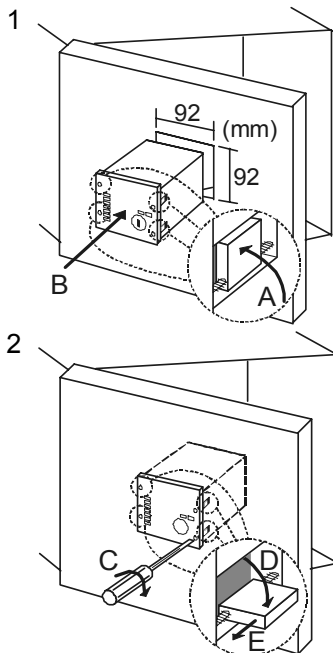

## Typical Connection (Automatic Mains Fail Application)

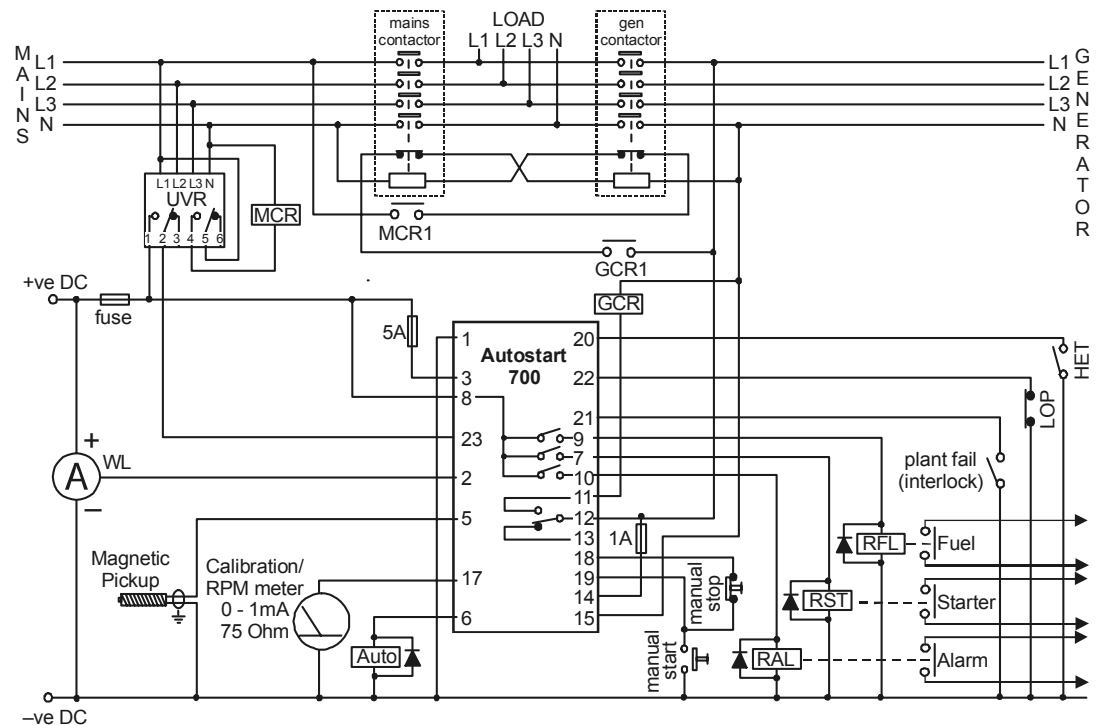

## Electrical Connection

Electrical connection to the Autostart 700 is via individual 1/4 inch blade terminals. All connections should be made with Autostart switched off and the wiring isolated from the DC/AC supply:-

### Pin Function

#### 1 Negative DC power supply

#### 3 Positive DC power supply

Before connection of these terminals, switch 1 (brown) at the rear must be set for the correct supply voltage:-

Switch 1 on (up) 12 VDC operation (9 - 16 V)  
Switch 1 off (down) 24 VDC operation (18 - 32 V)

The AS700 has an internal, self-recharging Ni-Cd battery that protects against DC supply brown-outs during engine cranking. The internal battery charge is maintained as long as pins 1 and 3 are connected to the DC supply. Note: the internal battery means that Autostart cannot be reset or powered down by removing the DC power connections.

Use a 5 Amp anti-surge fuse in the positive DC power line (pin 3).

#### 2 Charge fail input

This may be activated by external connection to negative DC. Pin 2 may therefore be connected to a charge alternator WL terminal (Autostart provides the necessary excitation current), or to the 'charge fail' output of a Murphy BC700 series charger, or direct to negative DC via relay contacts which close on fault.

Rear facia switch 3a (orange) allows further control of the front facia 'charge fail' LED indicator:-

Sw 3a on (up) Mains charger mode (LED always active)  
Sw 3a off (down) Charge alternator mode (LED overridden before engine startup)

#### 5 Magnetic pickup

Allows optional use of a magnetic pickup engine speed sensing. Rear facia switch S2 (red) must be set DOWN.

Connect one terminal of the pickup to pin 5, the other terminal to pin 1 or battery negative. The interconnection must use a two core and screen cable, with the screen earthed at one end only. If a magnetic pickup is not used, leave pin 5 open circuit.

#### 6 Auto mode output

Pin 6 gives a positive DC output (250mA max.) while the unit is switched to Auto mode.

#### 8 Positive DC (feed for relays)

Pin 8 is the common positive DC feed for the Crank, Fuel and Alarm outputs (pins 7, 9 and 10).

#### 7 Crank output

#### 9 Fuel output

Pins 7 and 9 give positive DC outputs (max. rating 16 Amps) for the control of engine fuel and starter motor circuits. Murphy recommend the connection of slave relays with suppressed coils between each output and the fuel/starter motor solenoid coils.

#### 10 Alarm output

Pin 10 gives a positive DC output (maximum rating 5 Amps) when Autostart has detected a fault and has shutdown the engine.

#### 11 Load relay: normally open contact

#### 12 Load relay: change-over contact

#### 13 Load relay: normally closed contact

The load relay is a volt-free set of SPCO relay contacts, used for the control of the generator contactor. The relay activates immediately after a generator start, provided that the generator is running within

normal frequency, voltage and oil pressure limits. Once the 'mains fail' input de-activates, the load relay will remain energised (keeping the generator on load) until the 'changeback' timer has expired.

- 14 Generator AC Live
- 15 Generator AC Neutral



**DANGER !  
HIGH VOLTAGE**

Autostart uses these terminals to sense generator voltage. Pins 14 and 15 are also optionally used to sense frequency (depending on the setting of rear switch S2). Frequency and voltage information are needed for the correct operation of the crank release, load relay and overspeed trip.

A 1 Amp anti-surge fuse should be connected in series with the generator live terminal (pin 14).

#### 16 Lamp Test input/output

Switch S5 on the top facia sets the DC polarity of this input/output. Used as an input, all LEDs light when this pin is connected to the correct polarity DC rail. As an output, this pin gives the selected polarity signal when the Autostart is switched to LAMP TEST.

WARNING: incorrect polarity switch setting and connection will result in internal shorting and damage to Autostart and panel wiring.

#### 17 RPM Meter/calibration output

This output, with the rear facia multi-turn potentiometer, is used to calibrate the Autostart's speed sensing circuit – this is necessary for the correct operation of the crank release, load switching and overspeed trip. After correct calibration, the output may also be used to drive a suitably scaled engine tachometer.

With the engine running normally and Autostart correctly calibrated, this terminal should give a 0.75mA output into a 75 Ohm meter.



These terminals may be wired as above, providing operator controlled starting and stopping of the engine when the Autostart is in test/manual mode. Alternatively, hard-wire pins 18 and 19 to battery negative to give an immediate engine start on switching to test mode.

#### 20 High Engine Temperature (HET) switch input

#### 22 Low Oil Pressure (LOP) switch input

These inputs are dedicated for use with low oil pressure (LOP) and high engine temperature (HET) fault switches. Top facia switches S2, S3 and S4 allow the inputs to be configured for fault switches which open or close on fault, with wiring to either positive or negative DC.

Each fault switch is wired between the input and the appropriate DC rail. An 'active' input results in the automatic, immediate shutdown of the engine, and the lighting of the appropriate front facia LED.

#### 23 Mains fail input

Use this input to initiate an automatic engine start. Pin 23 must be switched to battery positive when the generator is required to be on standby, and made open circuit to initiate an automatic start.

Further information: -

Document Ref.	Description
ms5893	AS700 sales bulletin and specification



**FRANK W MURPHY LTD.**

Church Road, Laverstock, Salisbury, SP1 1QZ, United Kingdom

tel: +44 (0)1722 410055 fax: +44 (0)1722 410088

email: sales@fwmurphy.co.uk web: www.fwmurphy.co.uk



*In order to consistently bring you the highest quality, full featured products, we reserve the right to change our specifications and designs at any time.*