

Generator Control Panels



MGC900 Series

- Available in Manual or Automatic Start and Stop per NFPA 110, Levels 1 or 2
 - 12 or 24 VDC Battery Voltage
 - Single Phase or 3-Phase
- Compact Design with Easy Installation and Access to Internal Components
- Two Enclosure Sizes Available

Description

The MURPHYMATIC® MGC900 Series generator panels provide economical, engine/generator, manual or automatic start/stop control for applications required by NFPA-110 approvals.

Models MGC900 to MGC903 are approximately 30% larger than the MGC910 to MGC913 models and have space for additional instruments and control relays, etc. For applications where space and clearance for maintenance and operation is restricted, MGC910 to MGC913 are the choice.

All MGC900 Series Models feature mechanical SWICHGAGE® instruments for engine oil, coolant temperature and hour, amp and voltmeters. For MGC900, 901, 902, and 903 Series models the low voltage and high voltage sections are divided by a metal partition.

The brain of the control panel is Murphy's solid-state design, A900 Series generator controller. It consists of a control display module and a relay module that combines automation and annunciation features into one unitized controller.

Basic Models

Models are available in two sizes and four configurations for 3-phase, 4-wire (3-wire optional) or 1-phase, 3-wire (2-wire optional) generators:

- **MGC900 - MGC910** Manual Start-Stop models
- **MGC901 - MGC911** Automatic Start-Stop models per NFPA-110, Level 1.
- **MGC902 - MGC912** Automatic Start-Stop models per NFPA-110, Level 2.
- **MGC903 - MGC913** Automatic Start-Stop models per NFPA-110, Level 2 (includes 8 additional unlabeled alarm points).

Standard Features (all models)

- All panels are housed in a shock mounted NEMA 1 drip-proof enclosure.
- Power OFF-ON toggle switch and start push button.
- Auxiliary starter relay. Contact rating: 12 volt, 40 amp/24 volt 16 amp.
- Oil Pressure SWICHGAGE®, 2 in (51 mm) dial, 0-100 psi (0-689 kPa) [6.89 bar].
- Temperature SWICHGAGE®, 2 in (51 mm) dial, 130-250°F (54-121°C), 12 ft. (3.7 m) capillary.
- AC voltmeter, 3-1/2 in. (89 mm) dial, ±2% full scale (specify range: 300 V or 600 V).
- AC ammeter, 3-1/2 in. (89 mm) dial, ±2% full scale (specify range: 50 to 4000 A).
- AC frequency meter, 3-1/2 in. (89 mm) dial, ±0.6%, 45-65 Hz.
- Voltage adjust rheostat.
- DC voltmeter, 12/24 VDC per application.
- DC ammeter, 0-60-0.
- Hourmeter, 5 digits.

NOTE: Current transformers (CT's) are not included.

- **Manual Start** models feature a **A900 Manual start controller and a pushbutton.**
- **Automatic Start** models feature a **A900 Automatic start controller.**

Specifications

■ Auto-Start Panel

- Power Requirements:
 - 12 VDC battery for 12 V models.
 - 24 VDC battery for 24 V models.
- Inputs: Ground or positive inputs for high temperature or low pressure sensors.
- Outputs: Auxiliary starter relay. Contact rating: 12 volt, 40 amp/24 volt 16 amp. 300 mA transistors for fault annunciation
- Operating Temperature: -4 to 140°F (-20/60°C).
- Cycle Crank Timer: Up to 8 attempts. Recrank on false starts (fixed 30 seconds).
- Crank/Rest Cycle Timing: 4-25 sec. (adjust).
- Shutdown Time Delay: 1-25 sec. (adjustable). Locks out low oil pressure and high temperature on start up.
- Crank Disconnect Speed Setting: From 30 to 8500 Hz.
- Overspeed Trip Point Setting: From 30 to 8500 Hz.
- Magnetic Pickup Input: Requires 2 Vrms min.

■ Manual Start Panel

- Power Requirements:
 - 12 VDC battery for 12 V models.
 - 24 VDC battery for 24 V models.
- Operating Temperature: -4 to 140°F (-20 to 60°C).

Dimensions for MGC900, MGC901, MGC902 and MGC903

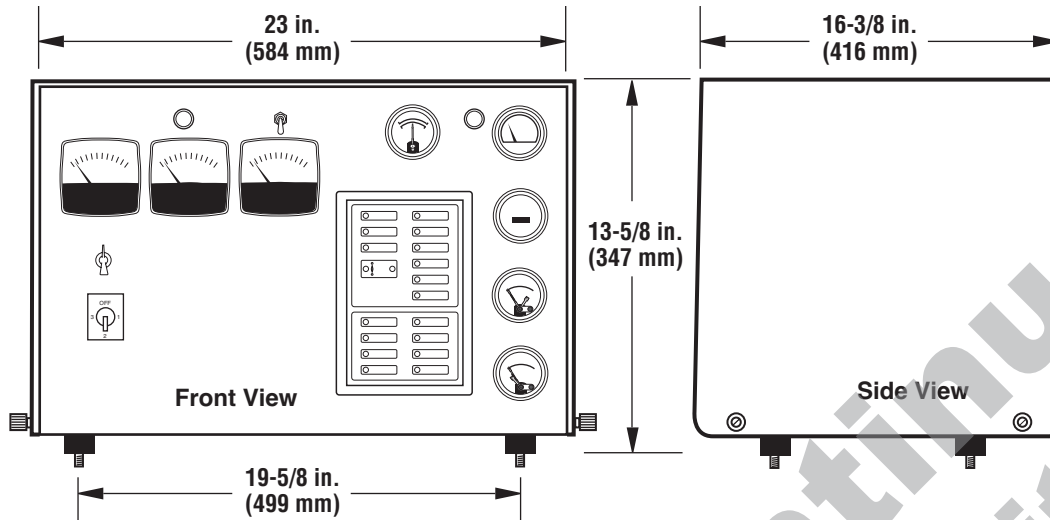

Dimensions for MGC910, MGC911, MGC912 and MGC913

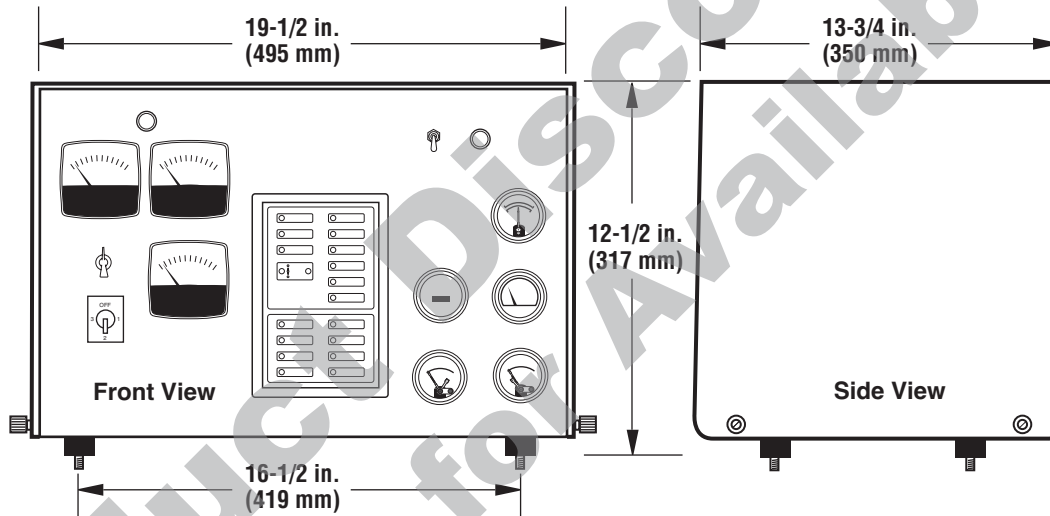

To Order Your MGC900 Series Panel See Specifications and Ordering Information Document MGC-9117M

Shipping Weights

MGC900; MGC901; MGC902; MGC903: 64 lbs (33 kg) approx.

MGC910; MGC911; MGC912; MGC913: 43 lbs. (22 kg) approx.

Shipping Dimensions

All Models: 26 x 21 x 18-1/2 in. (660 x 533 x 470 mm) approx.

Warranty

A limited warranty on materials and workmanship is given with this FW Murphy product. A copy of the warranty may be viewed or printed by going to www.fwmurphy.com/support/warranty.htm



FW Murphy

P.O. Box 470248
Tulsa, Oklahoma 74147 USA
+1 918 317 4100 fax +1 918 317 4266
e-mail sales@fwmurphy.com
www.fwmurphy.com

CONTROL SYSTEMS & SERVICES DIVISION

P.O. Box 1819; Rosenberg, Texas 77471; USA
+1 281 633 4500 fax +1 281 633 4588
e-mail sales@fwmurphy.com

MURPHY DE MEXICO, S.A. DE C.V.

Blvd. Antonio Rocha Cordero 300, Fracción del Aguaje
San Luis Potosí, S.L.P.; México 78384
+52 444 8206264 fax +52 444 8206336
Villahermosa Office +52 993 3162117
e-mail ventas@murphymex.com.mx
www.murphymex.com.mx

INDUSTRIAL PANEL DIVISION

P.O. Box 470248
Tulsa, Oklahoma 74147 USA
+1 918 317 4100 fax +1 918 317 4266
e-mail sales@fwmurphy.com
www.fwmurphy.com

FRANK W. MURPHY, LTD.

Church Rd.; Laverstock, Salisbury SP1 1QZ; U.K.
+44 1722 410055 fax +44 1722 410088
e-mail sales@fwmurphy.co.uk
www.fwmurphy.co.uk



Printed in U.S.A.

In order to consistently bring you the highest quality, full featured products, we reserve the right to change our specifications and designs at any time.