

SELECTRONIC® Annunciator



Series 1400

- 32 N.O. or N.C. Sensors for Alarm or Shutdown
- Alphanumeric Display
- Start/Run Timer
- Pre/Post Lube Timer
- Four Control Relay Outputs
- Field Adjustable
- EPROM Memory



Approved for Class I,
Division 1, Group D

Description

The Series 1400 is a microprocessor based fault annunciator. It tells in alphanumeric characters which protective device has signaled an alarm or caused equipment shutdown. Basic programming for each application is completed at Murphy and can be changed in the field by simply plugging in a new preprogrammed microchip. Information is called up and adjustments are made on a six-button keypad on the face of the unit.

Four SPDT relays are available for alarm and/or shutdown functions. A digital output version (S1400-SP) port interfaces with micro-controllers (7 bit straight binary code).

The S1400 and S1400-SP are powered from a 120 VAC or 12/24 VDC Class I, Division 1 explosion-proof power supply. The monitor is rated intrinsically safe.

Applications

Although designed primarily as an intrinsically safe annunciator for gas compressors, the Series 1400 can be programmed to monitor most engine or motor driven process applications, such as:

- Air compressors
- Gas compressors
- Fire pumps
- Sewage pumps
- Generators
- Process control
- Water treatment
- Burner systems
- Natural gas refueling

Features

- 32 sensor inputs (N.O. and/or N.C.) for alarm or shutdown
- Six-button keypad for easy operation and adjustments
- Digital output for interface with micro-controllers (optional)†
- Adapter for CD ignition interface with optoisolator input (optional)†
- Relay board expansion, provides 7 additional control relay outputs or binary representation of alarm/shutdown terminal number (specify)†
- Start-run timer
- Four control relay outputs
- Pre/Post lube time delay
- Typical standard program or customized*

† These options are NOT approved by CSA.

* Murphy provides various standard preprogrammed configurations. If a customer sensor input configuration is needed, Murphy will custom program your unit at the time you order. Call for quote.

Specifications

Power Consumption: 120 VAC (8 watts), 24 VDC (7.2 watts) or 12 VDC (2.5 watts).

Sensor Inputs: For up to 32 N.O. and/or N.C. inputs such as Murphy SWICHGAGE® instruments. Each input is factory programmed as a class A, B or C shutdown, alarm, or control function (specify).

Outputs: 4-SPDT relays, 4 A, 1/20 HP, 125/250 VAC/3A, 30 VDC.

NOTE: An isolation barrier (such as the Murphy LCDDT-1SB) must be used between the sensor switch and input terminals if the sensor output comes from any energy storing device such as a relay or transistor.

Timers: 4 adjustable for: lockout at start-up, test, prelude and postlube.

Time Delay: Up to 0.9 minutes before ignition grounds or electric motor stops.

Memory: Memory held in EPROM, 4k, 192 bytes of RAM.

Backup Battery: Rechargeable during normal operation. Provides up to 5 hours backup time.

Run Sensing: Either ignition or switch input.

Operating Temperatures: 32 to 122°F (0 to 50°C).

Storage Temperatures: -4 to 158°F (-20 to 70°C).

Case: ABS plastic, 1/4 DIN (90 x 90 mm).

Interface Output: Digital, 7 bit straight binary code.†

Display: Alphanumeric dot matrix, 2 line 32-character display.

Power Supply

Enclosure: *Explosion-proof, Class I, Division 1.*
Barrier: *Intrinsically safe barrier built into power supply, 120 VAC and 12 or 24 VDC power supply barrier with dry contacts relay functions such as:*

- Fuel valve
- Shutdown
- Alarm
- Control (Pre/Post Lube).

Dimensions

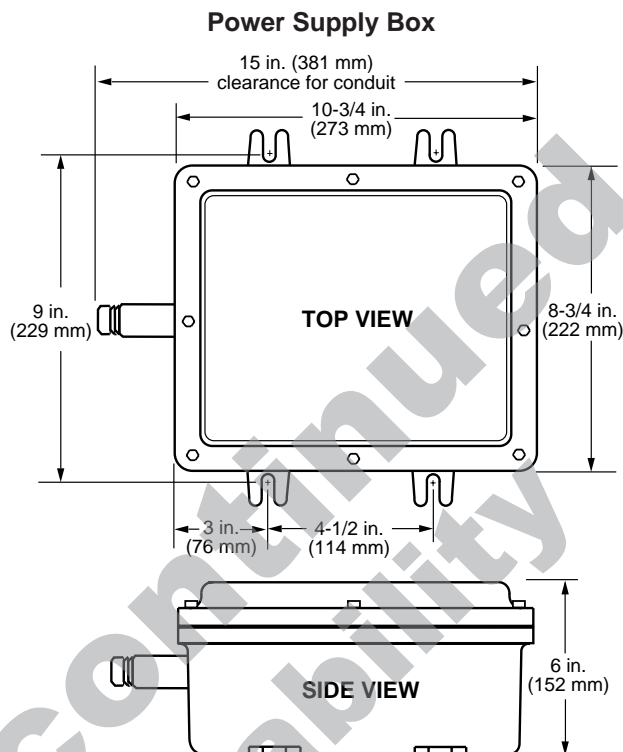
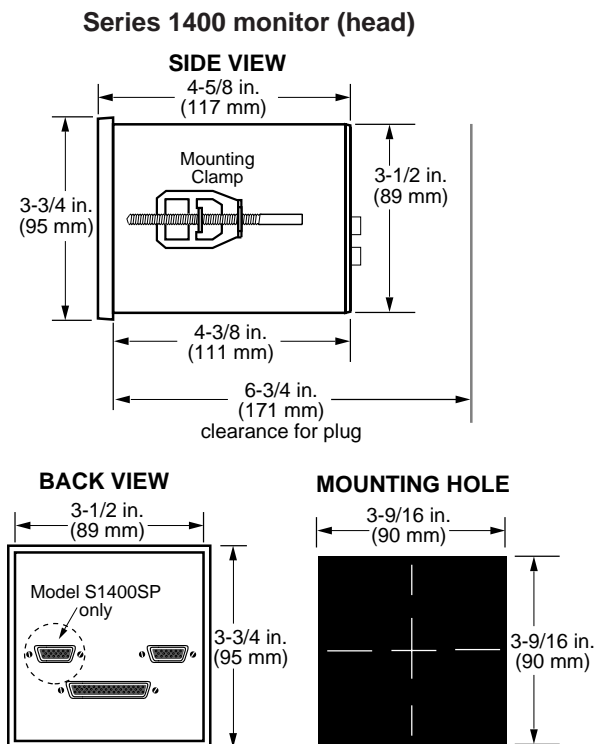

Series 1400 System

The basic **S1400** system consists of (1) the monitor, (2) a sensor input terminal strip assembly (rail mount) (3) a 36 inch (914 mm) flat ribbon cable for connecting the terminal strip to the monitor, (4) a power supply which includes the control Inputs/Outputs and an intrinsically safe barrier, with cable assembly. **S1400SP**; same as the S1400 system except the (1) monitor, includes an extra connector (port) for connection to S14BCM92 relay board expansion or for a digital output to interface with micro-controllers.

NOTE: Each unit is programmed to the customer specifications.

Accessories

S14RSA92 Adapter: Used to interface the S1400 opto-isolator input (also called run input) to CD ignition systems. (Not approved by CSA.)

S14BCM92 Relay Board Expansion: Can either be used to expand the S1400 relay capabilities an additional 7 relay control outputs, or for binary representation of the alarm/shutdown terminal number(s) to a PC board. (Not approved by CSA.)

LCDT-ISB Intrinsically safe barrier for N.O. sensors: Is designed to accept non-intrinsically safe normally open inputs and convert them to intrinsically safe outputs. Each LCDT-ISB provides for two (2) channels.

Warranty

A two-year limited warranty on materials and workmanship is given with this Murphy product. Details are available on request and are packed with each unit.

How to Order

Specify model numbers below:

S1400: Complete system (see "Series 1400 System" section on left).

S1400SP: Complete system (with digital output for interface).

To order individual components and accessories specify the model number:

Specify

Description

S1400H

Monitor (head) only

S1400HSP

Monitor (with digital output for interface) only

S1400TB32

Terminal block only

S1400CA36

Cable assembly only

S1400PS

Power supply only

S14RSA92

CD ignition adapter for run signal input

S14BCM92

Relay board expansion w/cable and connectors

LCDT-ISB

Intrinsically safe barrier for normally open sensors

Shipping Weights and Dimensions

	<i>Weight</i>	<i>Dimension</i>
S1400	28 Lb. (12.7 kg.)	20 x 14 x 12-1/2 in. (508 x 356 x 318 mm)
S1400H	2 Lb. (0.907 kg.)	6 x 6 x 6 in. (152 x 152 x 152 mm)
S1400HSP	2 Lb. (0.907 kg.)	6 x 6 x 6 in. (152 x 152 x 152 mm)
S1400TB32	2 Lb. (0.907 kg.)	12 x 7 x 4 in. (305 x 178 x 102 mm)
S1400CA36	2 Lb. (0.907 kg.)	6 x 6 x 6 in. (152 x 152 x 152 mm)
S1400PS	22 Lb. (9.98 kg.)	17 x 10 x 9-3/4 in. (431 x 254 x 248 mm)
S14RSA92	1 Lb. (0.453 kg.)	6 x 6 x 6 in. (152 x 152 x 152 mm)
S14BCM92	2 Lb. (0.907 kg.)	9-3/4 x 9 x 5-1/2 in. (248 x 229 x 140 mm)
LCDT-ISB	3 Lb. (1.3 kg.)	9 x 10 x 6 in. (229 x 254 x 152 mm)

In order to consistently bring you the highest quality, full featured products, we reserve the right to change our specifications and designs at any time.



■ **Frank W. Murphy Manufacturer**

P.O. Box 470248; Tulsa, Oklahoma 74147; USA
 tel. (918) 627-3550 fax (918) 664-6146
 e-mail fwmurphy@ionet.net

■ **Frank W. Murphy Southern Division**

P.O. Box 1819; Rosenberg, Texas 77471; USA
 tel. (281) 342-0297 fax (281) 341-6006
 e-mail murphysd@intertex.net

Printed in U.S.A.

■ **Frank W. Murphy, Ltd.**

Church Rd.; Laverstock, Salisbury SP1 1QZ; U.K.
 tel. +44 1722 410055 fax +44 1722 410088 tlx 477088
 e-mail sales@fwmurphy.co.uk

■ **Frank W. Murphy Pte., Ltd.**

26 Siglap Drive; Republic of Singapore 456153
 tel. +65 241-3166 fax +65 241-8382
 e-mail fwmsales@fwmurphy.com.sg

■ **Murphok Pty., Ltd.**

1620 Hume Highway; Campbellfield, Vic 3061; Australia
 tel. +61 3 9358-5555 fax +61 3 9358-5558

■ **Murphy de México, S.A. de C.V.**

Blvd. Antonio Rocha Cordero 300, Fracción del Aguaie
 San Luis Potosí, S.L.P.; México 78384
 tel. +52-48-206264 fax +52-48-206336
 e-mail murmexsl@infosel.net.mx

■ **Murphy Switch of California**

P.O. Box 900788; Palmdale, California 93590; USA
 tel. (805) 272-4700 fax (805) 947-7570
 e-mail sales@murphyswitch.com

■ **Frank W. Murphy France**

tel. +33 1 30 762626 fax +33 1 30 763989

0889797