

# TD35 Series 2-Channel Temperature SWICHGAGE®

## Installation and Operation Instructions

TD35-92177N  
Revised 03-02  
Section 10  
(00-02-0761)



Please read the following information before installing. A visual inspection of this product for damage during shipping is recommended before mounting. It is your responsibility to have a qualified person install this unit.

### GENERAL INFORMATION

## WARNING

BEFORE BEGINNING INSTALLATION OF THIS MURPHY PRODUCT

- ✓ Disconnect all electrical power to the machine.
- ✓ Make sure the machine cannot operate during installation.
- ✓ Follow all safety warnings of the machine manufacturer.
- ✓ Read and follow all installation instructions.

### Description

This microprocessor-based, temperature SWICHGAGE® that can simultaneously monitor two grounded† or ungrounded thermocouples types “J” or “K”. A back lit, LCD screen toggles between displaying the temperature of the 2 thermocouples in either °F or °C units (selectable, see *Adjustments and Operation Sequence*, opposite page). The screen can be locked for 15 seconds to view one channel exclusively.

The TD35 has adjustable trip points that can be used as control signals to initiate alarms and/or shut down equipment. Trip points settings are password protected (see *Adjustments and Operation Sequence*).

A built-in LED light alerts the user of a set point tripped condition. Membrane switch buttons, located on the face dial, are provided to select the thermocouple channel to be displayed. The switch buttons are also used for adjusting trip points.

### Specifications

**Input Voltage:** 8 to 35 VDC.

**Maximum Current:** 60 mA @ 8 VDC.

**Outputs:** Two isolated sinking transistors; 2 amp @ 50 VDC. Trip points can be selected to turn ON when signal reaches High trip point, turn OFF when signal reaches Low trip point; or turn ON when signal reaches Low trip point, turn OFF when signal reaches High trip point.

**Accuracy:** ±2% of reading or ±2°C; whichever is greater.

**Ranges:** J-type thermocouple: 32 to 1400°F (0 to 760°C).  
K-type thermocouple: 32 to 2000°F (0 to 1093°C).

**Ambient Temperature Compensation Range:**  
32 to 158°F (0 to 70°C).

**Temperature Coefficient:** 0.070°C/°C over compensation range.

**Operating Temperature:** 32 to 158°F (0 to 70°C).

**Storage Temperature:** -40 to 176°F (-40 to 80°C).

**Display:** LCD (Liquid Crystal Display).

**Trip Point Output:** Sinks to negative.

**Trip Point Accuracy:** ±2°F (±1.1°C) of reading.

**Minimum Reset Differential:** When reading falls 1 degree below the trip point value, the switch will reset.

**Bezel:** 430 Stainless Steel; standard polished; optional black.

**Case:** 1018 Polycarbonate/Polyester blend.

**Dial:** 3-1/2 in. (89 mm) diameter.

### Dimensions

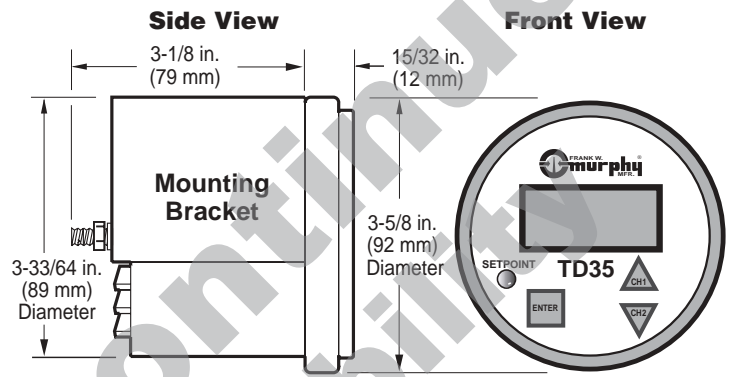

### Mounting Hole



### Back View

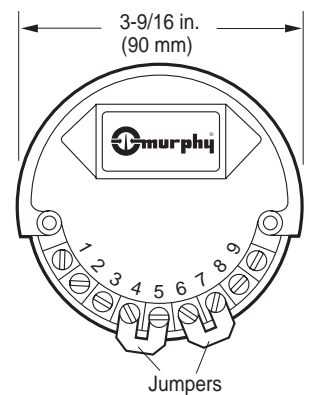

### TD35 Mounting Schematic

To mount the TD35 to your panel or wall, a 3-3/8 (86 mm) diameter mounting hole is required. Remove the mounting bracket and lock nuts (provided with the unit).

Insert the TD35 module from the front of the panel, see schematic below.

Replace mounting bracket and secure in place with the lock nuts.

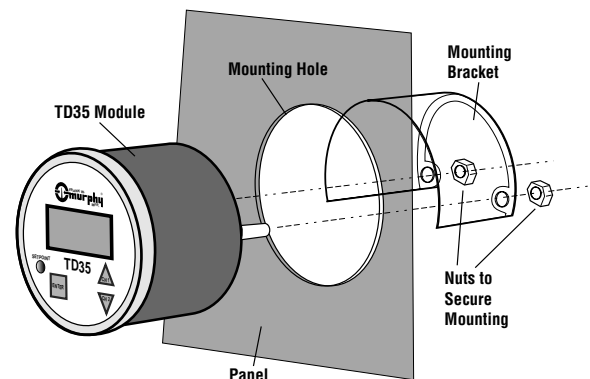

† Using grounded thermocouples introduces the risk of odd currents or voltages being imposed on the thermocouple signal which can affect the accuracy of the reading. This is an inherent problem of grounded thermocouples, the reason why we prefer ungrounded thermocouples.

## Wiring the TD35 Refer to Typical Wiring Diagram, below.



**WARNING:** Make sure Power is OFF. Keep ALL Power leads away from thermocouple and extension wire leads. Observe thermocouple wire leads polarity before wiring, refer to "Thermocouple Extension Wire Color Code Chart" below.

1. Connect a switch for display lights to TD35 **terminal 1**. See diagram below.
2. Connect Battery positive (+) to TD35 **terminal 2** (+).
3. Connect Battery negative (-) to **terminal 3** (-).
4. Remove jumper and connect negative lead of thermocouple 1 to **terminal 4** (-).
5. Connect positive lead of thermocouple 1 to **terminal 5** (+).
6. Remove jumper and connect negative lead of thermocouple 2 to **terminal 6** (-).
7. Connect the positive lead of thermocouple 2 to **terminal 7** (+).
8. If no thermocouple will be connected to a channel, leave that jumper installed.

## Typical Wiring Diagram

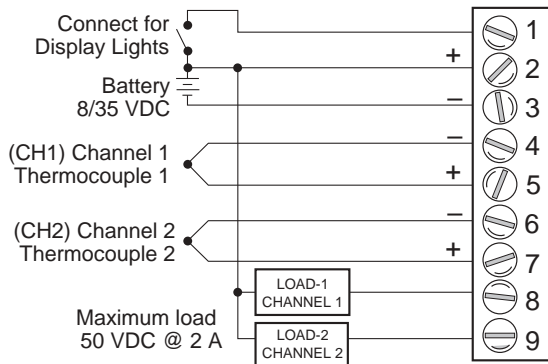

## Using Thermocouple Extension Wire



**CAUTION:** Non-Thermocouple wire will cause inaccuracy and erratic operation. Keep High Voltage Wiring such as spark plugs/ignition wires, away from thermocouple and extension wire.

Shielded Thermocouple extension wire should be used, it must be of the same material as the thermocouple leads (see the chart, below).

Metallic-shielded thermocouple wire is recommended. It provides electrical shielding as well as protection against wear and abrasion.

To prevent problems of interference from electrical noise, DO NOT route thermocouple wires in the same conduit or within 12 in. (305 mm) of ignition wires or alternating current conductors.

When connecting the thermocouple leads, twist the wire connections, then install wire nuts, such as ceramic, which have no metal insert.

Thermocouple Type	Thermocouple Extension Wire	Color Code/Material	
		Positive Lead	Negative Lead
J	Jx	White/Iron	Red/Constantan
K	Kx	Yellow/Chromel	Red/Alumel

## Operation Sequence and Adjustments

When power is applied, the TD35 performs an LCD test displaying *td35*, then it performs a normal scan. While the TD35 alternates between displaying the temperature of the channels every 2 seconds, both channels are updated internally every 0.5 seconds, and checked against their respective settings. The channel number being displayed appears next to the CHANNEL legend (see detail at right).

The scan can be locked to view one channel exclusively for 15 seconds by pressing CH1 (▲) or CH2 (▼). After 15 seconds, the unit will return to *Normal Scan*.

### Open Thermocouple Input

An open thermocouple input forces the TD35 monitor into upscale overrange. The display will show *OPEN*, the high trip point output will be turned ON and set point LED is lit alerting the operator.

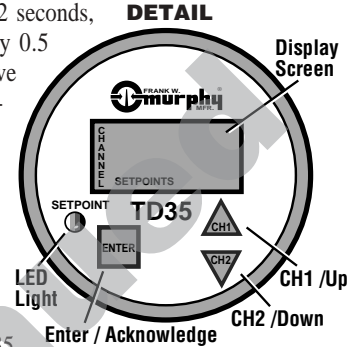

## Trip Points Access and Adjustments

1. To change trip points, press ENTER (■) while in *Normal Scan*. The TD35 will display *SET Pt.* Press ENTER (■) to display *Code*. Press ENTER (■) to display *0*. Press CH1 (▲) or CH2 (▼) to enter trip point access code number (35). Press ENTER (■). If the incorrect code is entered the screen will display *Err-Or*. The unit returns to *Normal Scan* after 5 seconds approximately. If the correct code was entered the Set point change is entered.
2. Set the TD35 to operate the trip point outputs on *Rising* or *Falling* temperature. Remember that both channels will be set to the same operation mode chosen, either *Hi-Lo* or *Lo-Hi*. Press CH1 (▲) or CH2 (▼) to select *Hi-Lo* (Rising) or *Lo-Hi* (Falling). If *Hi-Lo* is chosen, the trip point output for a channel is turned ON when temperature rises above the *Hi* trip point and stays ON until it falls below the *Lo* trip point for that channel. If *Lo-Hi* is chosen, the trip point output for a channel is turned ON when temperature falls below the *Lo* trip point and stays ON until it rises above the *Hi* trip point for that channel.
3. Press ENTER (■) to save the operation mode.
4. The *Hi* trip point for channel 1 is shown. Use CH1 (▲) or CH2 (▼) to adjust the trip point then press ENTER (■) to save the changes.
5. Repeat steps 4 and 5 for *Lo* trip point CH1 and *Hi* and *Lo* trip points of CH2. The screen will now display *Units* allowing to change the readout units (go to step 3, below). The TD35 will automatically return to *Normal Scan* in approximately 5 seconds if no button is pressed.

## Units Access and Adjustments (°F / °C)

1. To change units while in *Normal Scan* press ENTER (■). The screen will display *SET Pt.*
2. Press CH1 (▲), the screen will display *Units*.
3. Press ENTER (■) to display current readout *°FAH-* or *°CELS*.
4. Press CH1 (▲) or CH2 (▼) to change units readout.
5. Press ENTER (■) to acknowledge the change.



**FWMurphy**

P.O. Box 470248  
Tulsa, Oklahoma 74147 USA  
(918) 317-4100  
fax (918) 317-4266  
e-mail sales@fwmurphy.com  
www.fwmurphy.com

**CONTROL SYSTEMS & SERVICES DIVISION**  
P.O. Box 1819; Rosenberg, Texas 77471; USA  
(281) 342-0297 fax (281) 341-6006  
e-mail sales@fwmurphy.com

**MURPHY DE MEXICO, S.A. DE C.V.**  
Blvd. Antonio Rocha Cordero 300, Fracción del Aguaje  
San Luis Potosí, S.L.P.; México 78384  
+52-444-8206264 fax +52-444-8206336  
e-mail ventas@murphymex.com.mx  
www.murphymex.com.mx

**FRANK W. MURPHY, LTD.**  
Church Rd.; Laverstock, Salisbury SP1 1QZ; U.K.  
+44 1722 410055 fax +44 1722 410088  
e-mail sales@fwmurphy.co.uk  
www.fwmurphy.co.uk

**MURPHY SWITCH OF CALIFORNIA**  
41343 12th Street West  
Palmdale, California 93551-1442; USA  
(661) 272-4700 fax (661) 947-7570  
e-mail sales@murphyswitch.com  
www.murphyswitch.com

**MACQUARRIE CORPORATION**  
1620 Hume Highway  
Campbellfield, Vic 3061; Australia  
+61 3 9358-5555 fax +61 3 9358-5558  
e-mail murphy@macquarrie.com.au



In order to consistently bring you the highest quality, full featured products, we reserve the right to change our specifications and designs at any time.