

Autostart AS731 Generator Controller Installation Instructions

Section C: AS730 to AS731/AS732 retrofitting

mi6243
revision B, 10th September 2007
catalogue section 75

MURPHY

GENERAL INFORMATION

WARNING

BEFORE BEGINNING INSTALLATION OF THIS MURPHY PRODUCT

- ✓ Disconnect all electrical power to the machine
- ✓ Make sure the machine cannot operate during installation
- ✓ Follow all safety warnings of the machine manufacturer
- ✓ Read and follow all installation instructions

General

The Autostart AS731 and AS732 are full function, programmable controllers for the automatic or manual control of a standby generator.

Both units have similar features to the older AS730. This document gives compatibility details for use when fitting an AS731/732 in place of an AS730. Full information about the specification, installation and operation of the units may be found in the following documents:-

Doc. ref. Title

ms6127	AS731 bulletin and specification
ms6343	AS732 bulletin and specification
mi6128	AS731/732 installation section A: mounting/wiring
mi6129	AS731/732 installation section B: programming
mi6130	AS731/732 operation
mi6131	AS731/732 comms and AS7CN PC software
ms5261	AS730 bulletin and specification
mi5264	AS730 installation section A: mounting/wiring
mi5265	AS730 installation section B: programming
mi5266	AS730 communications and AS7CK PC software

Panel mounting

The AS730 and AS731/AS732 use the same casing and mounting procedure. Please consult document mi6128 for full details.

Front facia

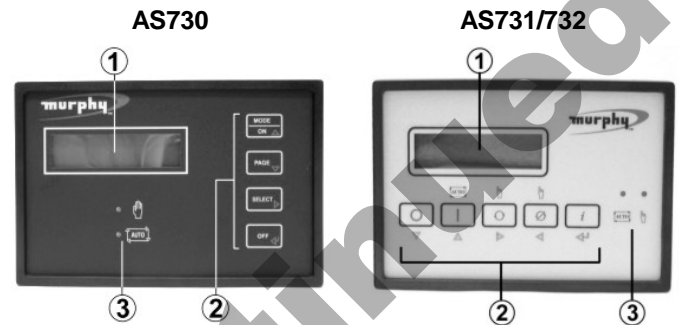

1. 2 line x 16-character backlit liquid crystal display
2. Operator control keys
3. Auto/manual mode LED indication

Rear facia

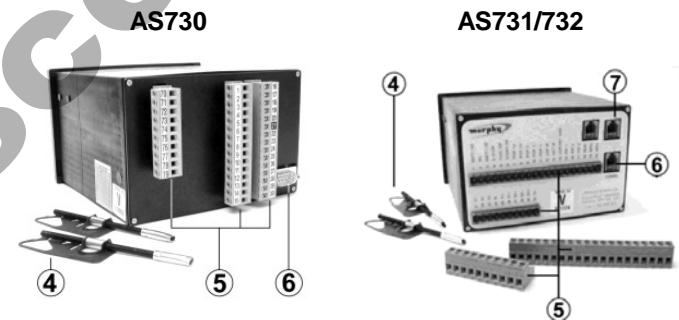

4. Mounting clamps
5. Screw terminal blocks
6. RS232 communication port (RJ11 connector)
7. (AS732 only) RS485 comms ports (2 x RJ45 connectors)

MURPHY

FRANK W. MURPHY LTD.
Church Rd, Laverstock,
Salisbury, SP1 1QZ, United Kingdom
tel: +44 1722 410055
fax: +44 1722 410088
email: sales@fwmurphy.co.uk
web: www.fwmurphy.co.uk

FW MURPHY
PO Box 470248
Tulsa, Oklahoma 74147, USA
tel: +1 918 317 4100
fax: +1 918 317 4266
email: sales@fwmurphy.com
web: www.fwmurphy.com



In order to consistently bring you the highest quality, full featured products, we reserve the right to change our specifications and designs at any time. MURPHY, the Murphy logo, are registered and/or common law trademarks of Murphy Industries, Inc. This document, including textual matter and illustrations, is copyright protected by Frank W Murphy Ltd., with all rights reserved. © 2007 Frank W Murphy Ltd.

ELECTRICAL CONNECTION



WARNING: DANGER OF INJURY OR DEATH. During normal operation, the AS730/731/732 is connected to high voltage circuits. Before connection, disconnection or handling of these units, ensure that all AC and DC power supplies are isolated. Connection to or disconnection from live wiring can also cause damage to Autostart internal components.

Electrical Compatibility

Most of the AS730 connections have electrically compatible counterparts on the AS731/AS732. Note, however, that the physical connectors and terminal numbering are **NOT** compatible. The AS730 has 3 vertically oriented terminals blocks, whereas the AS731/732 has 2 horizontal (non-compatible) blocks. Individual wiring connections must be unscrewed from the AS730 blocks, and re-connected into the appropriate AS731/732 terminal(s).

The guide below gives terminal number cross references, and details of compatibility, for use when migrating from AS730 to AS731/AS732. Typical wiring diagrams for both units are shown on page 4.

AS730 pin no.	AS731/ AS732 pin no.	Function/Compatibility
---------------	----------------------	------------------------

1	1	Negative DC power supply
3	3	Positive DC power supply Fully compatible.
2	2	Charge fail input Fully compatible. Program the AS731/732 as for the AS730.
4	4	Positive DC / Emergency stop Fully compatible.
5	19	Magnetic pickup input
-	20	Magnetic pickup input return On the AS730, one terminal of the (optional) magnetic is connected to pin 5; the other pickup terminal is connected to battery negative. On the AS731/732, a separate terminal (pin 20) is provided for the pickup return.
6	9	Output 1 (AS730) / output 2 (AS731/732)
7	10	Output 2 (AS730) / output 3 (AS731/732)
9	11	Output 3 (AS730) / output 4 (AS731/732)
10	-	Output 4 (AS730 only) AS730 programmable outputs 1 to 3 (pins 6, 7 and 9) are fully compatible with AS731/732 outputs 2 to 4 (pins 9, 10 and 11). AS730 output 4 is a relay based, negative DC output rated to 5 Amps max, with no direct equivalent on the AS731.
8	-	A800 enable (AS730 only) Pin 8 of the AS730 allows for direct connection to (and seam free operation of) the 'enable' terminal of a Murphy A800 annunciator. The AS731/732 does not have a directly compatible terminal. If an A800 'enable' connection is required, the same result can be achieved using a spare output:

AS730 pin no.	AS731/ AS732 pin no.	Function/Compatibility
---------------	----------------------	------------------------

8 (cont)	-	connect the slave relay as shown below (AS731/732 output 4 shown), and program the output to 'engine running'.
----------	---	--

The relay provides the A800 with the required positive DC input as soon as the AS731/732 detects an engine running state.

11	18	Remote start / mains fail Fully compatible. Program the AS731/732 as for the AS730 (open from / closed to positive DC to activate).
12	-	No connection (AS730)
13	-	No connection (AS730)
14	-	No connection (AS730)
15	-	No connection (AS730)
16	12	Input 1: (low) oil pressure
17	13	Input 2: (high) engine temperature
-	14	Input 1 and 2 return (AS731/732 only) These inputs allow connection to engine mounted fault switches or resistive senders. On the AS730, the 'return' side of the switch or sender is connected to battery negative DC. On the AS731/732, a separate connection (pin 14) is used for the return wiring, providing better immunity to signal noise. Program the AS731/732 as for the AS730.
18	15	Input 3
19	16	Input 4
20	17	Input 5 These programmable inputs are fully compatible. Programming of the AS731/732 is similar to the AS730, but each AS731/732 input can be individually set activate on open/closed/positive/negative signal.
21	-	Index pin (AS730 only)
22	5	Fuel output
23	6	Starter (crank) output Fully compatible.

ELECTRICAL CONNECTION (cont.)

AS730 AS731/ Function/Compatibility
pin no. AS732
pin no.

24 - Output 5 (AS730 only)
 AS730 pin 24 is a positive DC relay output, rated to 5 Amps. There is no equivalent connection on the AS731/732.

25 7 Output 6 (AS730) / output 1 (AS731/732)
26 8 Output 6 (AS730) / output 1 (AS731/732)
 AS730 output 6 (pins 25 and 26) is a pair of volt free, normally open contacts, rated to 5 Amp max.

AS731/732 pins 7 and 8 are fully compatible with the above, but are designated output 1.

Program AS731/732 output 1 as for AS730 output 6. The factory default programming for both is 'gen contactor'.

27 - Manual stop input (AS730 only)
28 - Manual start input (AS730 only)
 On the AS730, these pins allow optional connection of panel mounted manual mode start and stop push buttons.

The AS731/732 has no equivalent, dedicated connection, since manual mode starting and stop can be carried out from the front facia.

If remote panel controls are required, AS731/732 inputs 3 to 5 (if spare) can be programmed to 'manual start' and 'manual stop'. To ensure compatibility with the AS730 wiring, the 'manual start' input must be set to activate on 'closed to negative', and the 'manual stop' input must be set to activate on 'open from negative'.

29 - Generator AC (AS730 only)
30 - Generator AC (AS730 only)



WARNING: HIGH VOLTAGE - DANGER OF INJURY OR DEATH.

On the AS730, these (frequency sensing) connections are required in addition to the multi-phase connections on pins 70 – 73.

On the AS731/732, frequency sensing is done through pins 21 – 24 (see below).

70 21 Generator AC phase L1
71 22 Generator AC phase L2
72 23 Generator AC phase L3
73 24 Generator AC neutral



WARNING: HIGH VOLTAGE - DANGER OF INJURY OR DEATH.

These connections are electrically compatible. Program the AS731/732 as for the AS730.

AS730 AS731 Function/Compatibility
pin no. AS732
pin no.

74 25 CT L1
75 26 CT L1 return
76 27 CT L2
77 28 CT L3 return
78 29 CT L3
79 30 CT L3 return

These connections are electrically compatible. Program the AS731/732 as for the AS730.

Communications

RS232 communication

Both AS730 and AS731/732 have RS232 serial ports on the rear facia, allowing local or remote (modem) communication with a PC running Murphy software. AS730 communication is via a 9 way D-type connector, which also requires an external RS232 interface unit (models AS7CC or AS7CD). The AS731/732 uses an RJ11 (telephone type) connector and does not require a separate interface.

The communication leads used with the AS730 cannot be used or easily modified for operation with an AS731/732. Replacement leads and adaptors are available from your Murphy representative.

RS485 communication

AS732 units feature RS485 MODBUS communications, accessed via 2 x RJ45 connectors on the rear facia. The AS730 and AS731 do not have an RS485 facility.

For full details about AS731/732 communications, PC software and accessories, please refer to document mi6131.

ELECTRICAL CONNECTION (cont.)

AS730 typical wiring diagram (automatic mains fail generator)

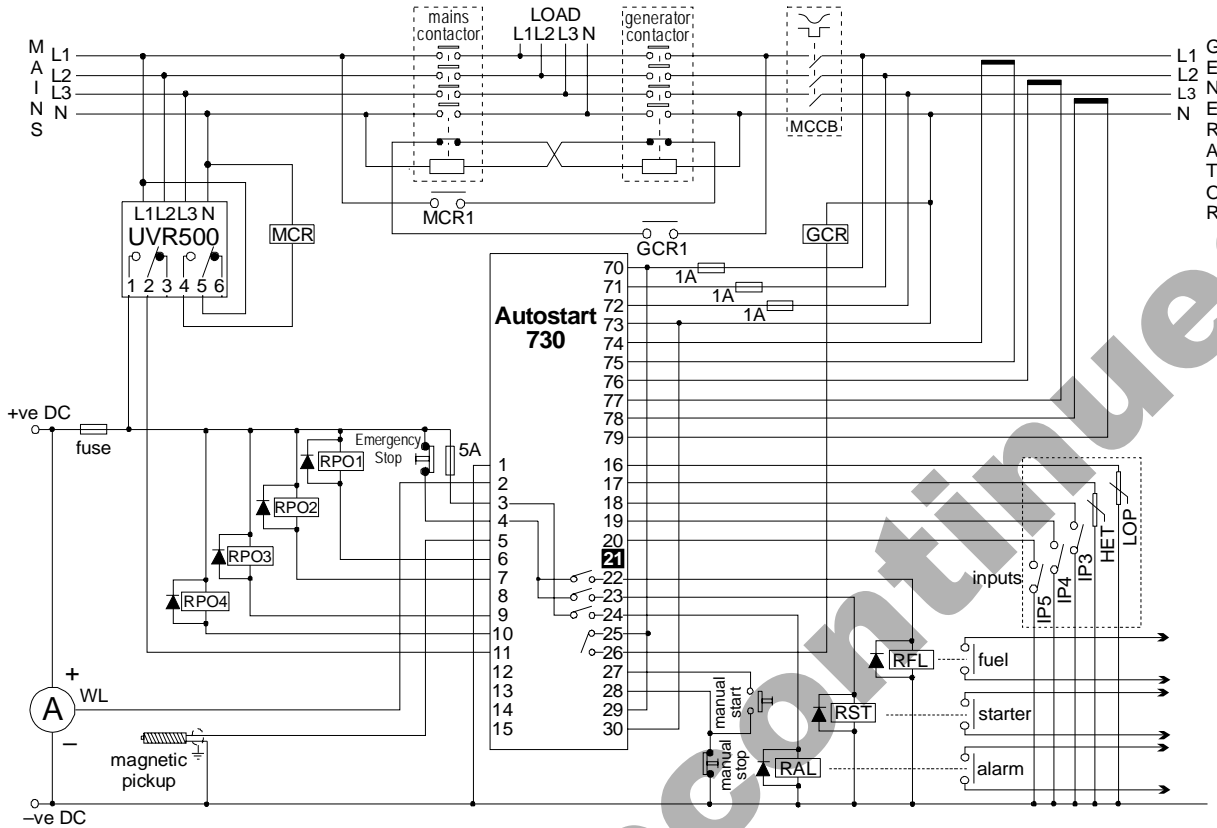

AS731 typical wiring diagram (automatic mains fail generator)

