

# ECD series Earth Current Detectors Installation Instructions

yi6325  
revision C, 6<sup>th</sup> March 2008  
catalogue section 75



Please read the following information before installing. A visual inspection of this product for damage during shipping is recommended before installation. It is your responsibility to ensure that qualified mechanical and electrical technicians install this product. If in doubt, please contact your local Murphy representative.

## GENERAL INFORMATION

WARNING

**BEFORE BEGINNING INSTALLATION OF THIS MURPHY PRODUCT**

- ✓ Disconnect all electrical power to the machine
- ✓ Make sure the machine cannot operate during installation
- ✓ Follow all safety warnings of the machine manufacturer
- ✓ Read and follow all installation instructions

### Description

A range of economical AC earth leakage detection relays, the ECD is designed to protect electrical equipment and wiring from earth fault currents. Each device typically operates with a circuit breaker or contactor, isolating the equipment's power supply following an earth fault.

**IMPORTANT: the ECD is not classified for use as a personnel protection device against direct contact with a high voltage supply.**

The ECD is a 'residual current' device. Equipment or distribution system fault currents are measured by passing the installation cables through an integral core balance transformer (CBT). During normal operation, outward and return currents at any instant are largely balanced and the CBT output is zero or slightly above zero. During earth fault conditions, outward and return currents are not balanced: the net AC current causes an output from the CBT; this output current is detected and the trip relay operates. Note: DC fault currents are NOT detected.

The ECD current detection circuit combines stable amplification of the transformer output with an ability to give high sensitivity and fast operating speeds. Protection from excessive fault current and supply transients is fitted as standard, as is filtering to allow use with chopped waveform and variable drive applications.

An AC earth fault results in the energisation and latching of a single pole change-over relay. The ECD is reset by momentary disconnection of the auxiliary power supply. Auto reset is achieved when the ECD takes its power supply from downstream of the circuit breaker.

Each ECD uses a robust, glass filled nylon case. A 31mm aperture in the casing allows the installation cabling to pass



### Specification

<b>Power supply:</b>	
operating voltages (ranges) <i>(all for 50/60Hz.)</i>	110V AC (100 – 120 V) 240 V AC (200 – 250 V)
power consumption	< 100mA
<b>Control:</b>	
trip current/delay	see 'familiarisation' overleaf for standard model options <i>(ratings for resistive load)</i>
<b>Relay output:</b>	
	SPDT contacts, rated 3A @ 250V AC/30V DC, 1A @ 440V AC
<b>Physical:</b>	
operating temperature	-25 to +60°C
weight (with EMA)	approx. 330 g

through the integral core balance transformer. For larger diameter cables, the ECD may be wired with external, large diameter core balance transformers.

The ECD is factory set to either 10mA, 30mA or 300mA trip currents, and is available in 230 VAC or 110 VAC supply voltage variants. A 'test' feature may activated by a front facia push-button, or via wiring to remote panel button, switch or relay contacts.



**FRANK W MURPHY LTD.**  
Church Road, Laverstock, Salisbury, SP1 1QZ, United Kingdom  
tel: +44 (0)1722 410055 fax: +44 (0)1722 410088  
email: sales@fwmurphy.co.uk web: www.fwmurphy.co.uk



In order to consistently bring you the highest quality, full featured products, we reserve the right to change our specifications and designs at any time.

## GENERAL INFORMATION

### Familiarisation

For each ECD ordered, the following is supplied:-

- 1 x ECD module
- These instructions

Model EMA fixing plate (complete with 2 securing screws) may also be supplied.

The side of each ECD has a part number and ratings label (see photo right), which should be checked against the specification required. Standard models are:-

Stock code	Supply voltage	Nominal trip current *	Nominal trip delay *	Test button
76.70.1201	110 VAC	10 mA (fixed)	20 mS (fixed)	Integral or remote
76.70.1202	240 VAC	10 mA (fixed)	20 mS (fixed)	Integral or remote
76.70.1203	110 VAC	30 mA (fixed)	20 mS (fixed)	Integral or remote
76.70.1204	240 VAC	30 mA (fixed)	20 mS (fixed)	Integral or remote
76.70.1205	110 VAC	300 mA (fixed)	20 mS (fixed)	Integral or remote
76.70.1206	240 VAC	300 mA (fixed)	20 mS (fixed)	Integral or remote

Notes:

a) nominal trip currents and delays are based on 50Hz use. When used with 60Hz systems, each ECD is approximately 10% more sensitive than the rated level.

b) models 76.70.1207 through 76.70.1212 featured two potentiometers for the adjustment of trip current level and response time. Production of these models was discontinued in March 2007. For installation and operation details of these models, please contact our engineers.

### Front facia

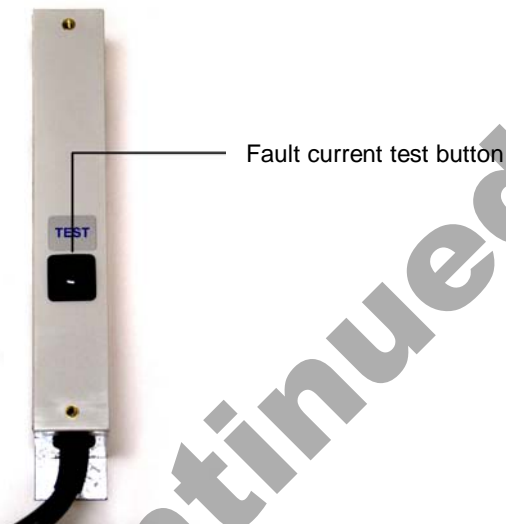

### Side facia

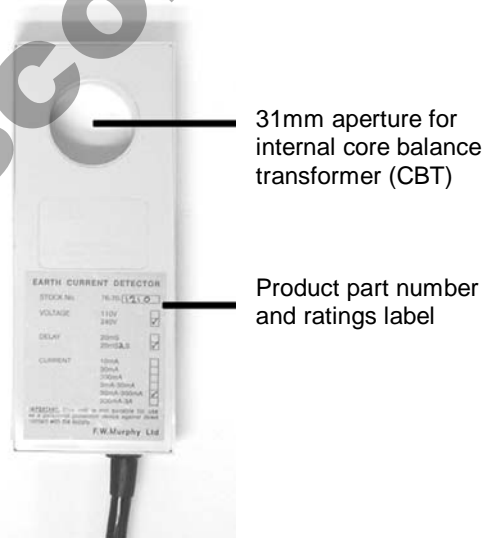

## PANEL MOUNTING

The ECD is typically mounted inside the equipment or distribution panel that is being monitored. Position the ECD in a location that is free from ingress of moisture or excessive amounts of dust/dirt, and from excessive temperature build-up.

ECD positioning must also allow:-

- access for the AC cabling that is to be monitored (or remote core balance transformer wiring). The cabling needs to pass through the 31mm aperture in the ECD case.
- access for the other electrical connections (details below).

The ECD may be directly mounted to a panel back-plate using two 3mm threaded inserts (diagram right). The inserts are spaced 136mm apart, requiring the 3mm screws to be applied from the rear of the back-plate. Alternatively, optional mounting plate model EMA (supplied with 2 screws) may be attached to the ECD, allowing screw fixing from the front.

### Dimensions and fixing (mm)

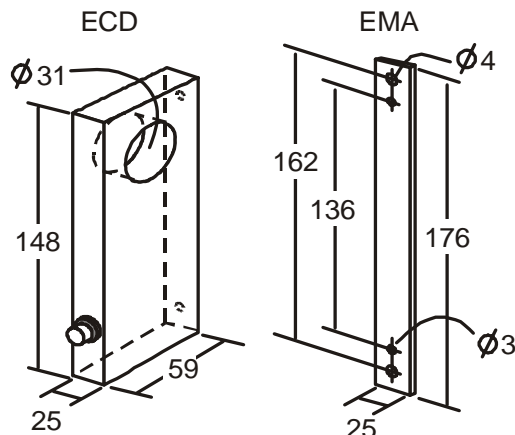

# ELECTRICAL CONNECTION



**WARNING: HIGH VOLTAGE CONNECTIONS. DANGER OF ELECTRIC SHOCK.**

Before connection or disconnection of the terminals below, ensure that all wiring is isolated from the AC supply.

The ECD's power supply, test input and relay output are connected via a 300mm, 6-core flying lead. The AC phase cables to be monitored are passed through the integral core balance transformer (through the 31mm aperture in the case), or through a remote CBT - see examples 1 and 2 below for typical connection diagrams.

## Power supply, test input and relay output

Connection is via a 6-core flying lead, supplied pre-stripped without terminals. Colour coding is as follows:-

**Wire colour      Function**

**Red      Power supply live 1**

**Black      Power supply neutral / live 2**

The AC auxiliary power supply. Power can be from phase to neutral or phase to phase supplies of the correct voltage. Each unit's nominal supply voltage (110 or 240 VAC) is marked on side label: please see specification for operating voltage ranges.

**Blue      Test input**

Connection of the blue wire to the AC live supply (typically using a remote push-to-make switch) causes a fault level current to pass through the internal CBT core, giving a full, effective test of the CBT coil, detection circuit and trip relay.

On ECDs with fixed current and delay ratings (those units without adjustment potentiometers), the TEST circuit may also be activated by pressing the front facia TEST button.

**White      Relay output, normally closed contact**

**Yellow      Relay output, changeover contact**

**Green      Relay output, normally open contact**

In normal operation the ECD relay is de-energised. The relay energises and latches when the fault current and delay limits are exceeded. To reset the ECD and de-energise the relay, disconnect the power supply.

For relay contact current/voltage ratings, please refer to the specifications on page 1.

## AC phase cabling (using integral CBT only)

Pass the cables of the AC system to be monitored through the core balance transformer aperture as shown in example 1 below. Single or multi-phase current balanced systems may be monitored in this way, assuming that all cables are passed through the ECD aperture.

As a rough guide, the 31mm ECD aperture will allow the following combinations of cable cores and sizes:-

No. of cables	Maximum overall diameter of each cable*
2	15mm
3	14mm
4	12mm

\*For equivalent conductor cross-sectional area and system current ratings, please consult local wiring regulations.

## AC phase cabling (using remote core balance transformers)

Where the AC system cabling is too large to pass through the ECD's 31mm aperture, or if a trip current of more than 3 Amps is needed, use remote, larger diameter core balance transformers such as the Murphy ERC series. Typical wiring is as shown in example 2 below.

## Typical connection

Example 1: typical connection using integral core balance transformer and circuit breaker, with auto reset of ECD.

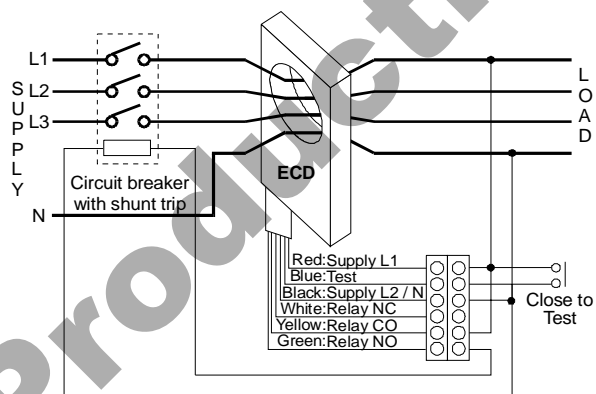

Example 2: typical connection using remote core balance transformer and circuit breaker, with auto reset of ECD.

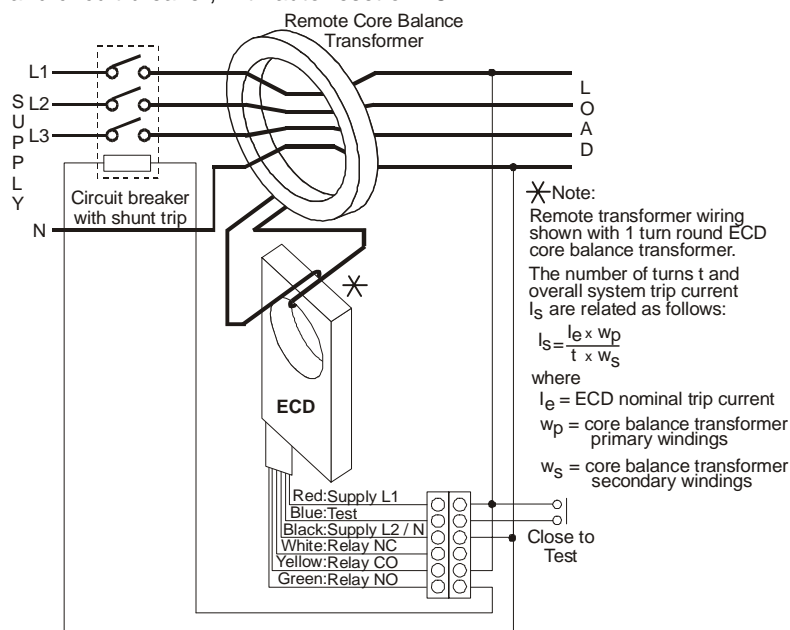

## ELECTRICAL CONNECTION (cont.)

The remote CBT size (in particular the inside diameter) needs to be chosen according to the number and outside diameter of the cables. As a rough rule for circular CBTs:-

No. of cables	Minimum internal diameter of remote CBT
2	2 x cable diameter
3	2.2 x cable diameter
4	2.5 x cable diameter



**WARNING: unless a 1:1 ratio remote core balance transformer is used, the trip current rating marked on the side of the ECD will NOT be the trip current of the overall system.**

The overall system trip current  $I_s$  is determined by the formula:-

$$I_s = \frac{I_e \times W_p}{T \times W_s}$$

Where:-

$I_e$  = the ECD trip current setting

$W_p$  = the number of remote CBT primary windings

$W_s$  = the number of remote CBT secondary windings

$T$  = the number of turns around the ECD core made by the CBT secondary wiring

More usually, the required trip current is known, and the other variables (usually ECD trip rating or number of turns) must be selected to achieve the required overall rating. The formula

may therefore be re-arranged into several forms, e.g.:-

$$T = \frac{I_e \times W_p}{I_s \times W_s} \quad I_e = \frac{T \times I_s \times W_s}{W_p}$$

Example:

A three phase distribution system with large cable diameters is required to have a maximum earth fault trip current of, say, 5 Amps. The system cabling is too large to be passed through the ECD's 31mm core balance transformer, so a remote CBT from the Murphy ERC range is selected (with an internal diameter large enough to accommodate the cables).

Murphy ERC core balance transformers have an effective ratio of 100:1, i.e. a system ('primary') fault current of 5 Amps results in a CBT ('secondary') output of  $5 \times 1/100$ , or 50 mA.

One of several ECD units might be selected to achieve the required trip level:-

- An ECD with a fixed 30mA trip level, with the remote CBT secondary wire making a single turn around the ECD transformer aperture. Calculating backwards, this setup gives a system trip current of 3 Amp less than the 5 Amp required limit, but possibly acceptable.
- An ECD with a fixed 300mA trip level. In order to operate this 300mA ECD, the remote CBT secondary wire (with 50mA fault current) must use 6 turns through the ECD transformer aperture.
- An ECD with a variable trip current, e.g. 30 to 300mA. This gives the greatest flexibility, both for accurate setting of the trip current, and for allowing fine adjustment of the trip current and time delay in the event of intermittent tripping.

## SETTING AND OPERATION

### General

The earth fault trip current and delay response for each system must be chosen in accordance with the local wiring regulations and equipment / distribution system specification.



**WARNING: incorrect selection/adjustment of earth fault trip current and time delay, when combined with excessive earth (fault) system currents, may result in equipment damage and subsequent personal injury.**

All ECD units have a time response that varies with the level of fault current: higher fault currents result in a quicker relay operation. Note also that the ECD trip delay is only part of the overall time response: the response times of auxiliary relays, circuit breakers or contactors must be factored into any maximum trip time requirements.

### Fixed rating units

Models 76.70.1201 through to 76.70.1206 have fixed (non-adjustable) trip characteristics. The trip time is a nominal 20mS, with model-dependent nominal trip currents of 10mA, 30mA or 300mA. ECDs are designed to trip with a margin of safety, and are calibrated to meet or exceed the trip current/time requirements of BS4293. ECDs with a fixed current and delay have trip characteristics as follows:-

- Tripping will not occur for fault currents below 50% of the rated current.
- For fault currents at 100% of rated current or above, ECD tripping is guaranteed to occur within 150mSec. Tripping may also occur (within an unspecified time) at fault currents between 100% and 50% of the rated current.
- For fault currents at 500% of rated current or above, tripping is guaranteed to occur within the nominal trip time (20mS). Fault currents below 500% of nominal may result in trip times slower than 20mS.

### Variable rating units

Models 76.70.1207 through to 76.70.1212 featured two potentiometers for the adjustment of trip current level and response time. Production of these models was discontinued in March 2007. For installation and operation details of these models, please contact our engineers.

### Maintenance

To check operation of the ECD, earth fault testing of the overall system should be carried out at regular intervals. The ECD itself is designed to be largely maintenance free and contains no user serviceable parts. No attempt should be made to dismantle the unit: damage may result to the sensitive internal components and any remaining warranty will be invalidated.

Maintenance is limited to checking that unit is kept free from dust or moisture. With the power isolated, the unit may be cleaned using a dry, lint-free cloth.

ECD units are supplied with a 2 year warranty on materials and workmanship. Full details of our warranty terms are available at [www.fwmurphy.co.uk/warranty](http://www.fwmurphy.co.uk/warranty).

Production Discontinued

Production Discontinued



**FRANK W MURPHY LTD.**

Church Road, Laverstock, Salisbury, SP1 1QZ, United Kingdom

**tel:** +44 (0)1722 410055 **fax:** +44 (0)1722 410088

**email:** sales@fwmurphy.co.uk **web:** www.fwmurphy.co.uk



USA - ISO9001:2000 FM 28221  
UK - ISO9001:2000 FM 29422

*In order to consistently bring you the highest quality, full featured products, we reserve the right to change our specifications and designs at any time.*