

# 751602 / 751603 series

## Engine and Pump Diagnostic Centres

ss6351  
24th April 2003  
catalogue section 30



- **Fault protection panels for engines and pumps**
- **Swichgage® indication and automatic fault shutdown**
- **Compact and easy to install**

### Description

751602 and 751603 panels provide simple and reliable fault protection for engine-driven and pump applications.

The panels use the accurate and dependable Murphy Swichgage® for status indication and adjustable limit fault shutdown. Both panels feature Swichgages® for engine oil pressure (0 - 100 psi / 7 Bar) and coolant temperatures (50 - 120°C), plus a front facia emergency stop push-button. Model 751603 additionally has a 0 - 20 Bar water pressure Swichgage®, with user-adjustable shutdown limits for high and low pump pressure.

The 75160 series is designed for use with 12V engines with energised-to-run type fuel solenoids. Automatic fuel shutoff is by use of Murphy 518APH magnetic switch contacts. The switch is manually held in reset during engine/pump startup, but will release and latch following an engine fault.

75160 panels use a rugged black plastic, surface-mounted casing. Standard models are supplied complete with a 2 metre oil line and adaptors, 3 crimped wires for electrical connection (battery positive, negative and fuel/shutdown output) and a wiring diagram. A 2 metre water pressure utility line is additionally supplied with the 751603.

### Warranty

A two year limited warranty on materials and workmanship is given with this Murphy product. Full details are available on request and at [www.fwmurphy.co.uk/warranty](http://www.fwmurphy.co.uk/warranty).

### Dimensions

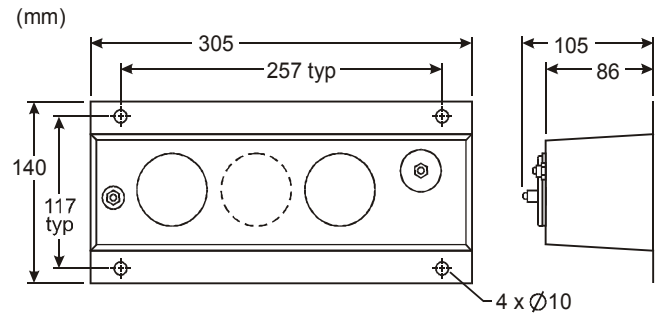

### How to order

Stock code	Model/description
B2647	751602 panel, 0 - 100psi, 50 - 120°C
B2643	751603 panel, as 751602 plus 0 - 20 bar pump pressure Swichgage®

**MURPHY**

**FW Murphy**  
PO Box 470248  
Tulsa, Oklahoma 74147, USA  
tel: +1 918 317 4100  
fax: +1 918 317 4266  
email: [sales@fwmurphy.com](mailto:sales@fwmurphy.com)  
web: [www.fwmurphy.com](http://www.fwmurphy.com)

**CONTROL SYSTEMS AND SERVICES DIVISION**  
PO Box 1819, Rosenberg, Texas 77471, USA  
tel: +1 281 633 4500  
fax: +1 281 633 4588  
email: [sales@fwmurphy.com](mailto:sales@fwmurphy.com)

**MURPHY DE MEXICO S.A. DE C.V.**  
Blvd. Antonio Rocha Cordero 300, Fracción del Aguaaje  
San Luis Potosí, S.L.P. México 78384  
tel: +52 444 8206264  
fax: +52 444 8206336  
**Villahermosa office tel:** +52 993 3162117  
email: [ventasamex@murphymex.com.mx](mailto:ventasamex@murphymex.com.mx)  
web: [www.murphymex.com.mx](http://www.murphymex.com.mx)

**FRANK W. MURPHY LTD.**  
Church Rd, Laverstock, Salisbury, SP1 1OZ, UK  
tel: +44 1722 410055  
fax: +44 1722 410088  
email: [sales@fwmurphy.co.uk](mailto:sales@fwmurphy.co.uk)  
web: [www.fwmurphy.co.uk](http://www.fwmurphy.co.uk)

**MURPHY SWITCH OF CALIFORNIA**  
41343 12th Street West,  
Palmdale, CA 93551-1442, USA  
tel: +1 661 272 4700  
fax: +1 661 947 7570  
email: [sales@murphyswitch.com](mailto:sales@murphyswitch.com)  
web: [www.murphyswitch.com](http://www.murphyswitch.com)

**MACQUARRIE CORPORATION**  
1620 Hume Highway,  
Campbellfield, Victoria 3061, Australia  
tel: +61 3 9358 5555  
fax: +61 3 9358 5558  
email: [murphy@macquarrie.com.au](mailto:murphy@macquarrie.com.au)



*In order to consistently bring you the highest quality, full featured products, we reserve the right to change our specifications and designs at any time.*