

# SM82

## Automatic Battery Chargers

ys6375  
18<sup>th</sup> October 2004  
catalogue section 40

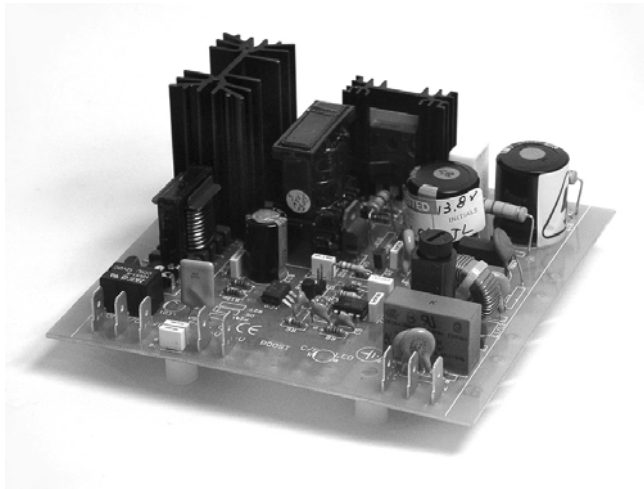

### Description

The SM82 is a fully automatic battery charger / power supply that may be used in a wide range of industrial applications. Switch mode power supply technology provides a compact, lightweight design with high power efficiency and low heat dissipation. Fast, accurate and smooth charging ensures optimum battery life and reliability.

The SM82 is intended for continuous float charging and standby battery applications, including standby engines, pumps and generators. The DC output gives rapid charging at maximum current until the battery reaches a 'knee point' voltage (13 VDC for 12V lead acid). The output then ramps down to its float voltage, maintaining optimum battery charge and supporting static loads up to the maximum rated current:-

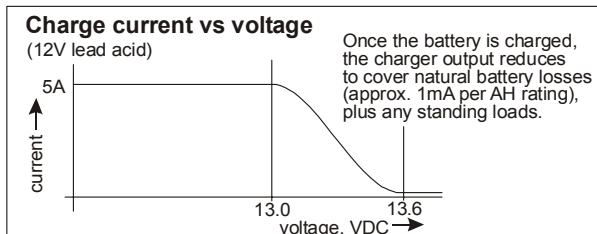

The SM82 output has very low ripple (< 1%), allowing safe use with vented lead acid, VRLA, Plante or NiCd batteries.

A 'boost' mode provides an increased voltage output where required. Boost mode is selected by linking two terminals, typically via a remote panel switch or time relay – see calibration table overleaf for details of float and boost voltages.

Two (switched negative relay) outputs are fitted for remote signalling of 'on charge' and 'charge fail' conditions.

The chargers have an open circuit board construction, designed for surface mounting in an enclosed panel. Electrical connection is via 6mm blade terminals. The SM82 is supplied for use with 195 to 277 VAC nominal power supplies, but a moveable circuit board link allows operation with 95 to 135 VAC supplies.

- **High rate, fully automatic float charging: 5A/12V or 3A/24V**
- **Compact, lightweight design**
- **Low ripple output, suitable for lead acid, Ni-Cd or VRLA cells**
- **Float and boost modes**
- **On charge & charge fail outputs**

### Product specification

power supply:	SM82125	SM82243
operating voltage range	195 – 277 VAC (240V setting) 95 – 135 VAC (110V setting)	
operating frequency range	47 – 400 Hz.	
<b>DC charge output:</b>		
maximum current, A DC	5	3
nominal voltage, V DC	12	24
float/boost voltages	see table overleaf	
line regulation	< 1%	
load regulation	< 1%	
output ripple	< 1%	
<b>charge fail output:</b>		
configuration	switched negative relay contacts: NC (–ve DC during fault / power down) NO (–ve DC during normal operation)	
contact rating	1A @ 30 VDC (resistive load)	
<b>general:</b>		
operating temperature	–10 to +55 °C	
overall dimensions (w x h x d)	133 x 130 x 70 mm (see diagram overleaf)	
weight	approx. 0.56 Kg (1.24 lbs)	
Electromagnetic Compatibility	89/336/EEC	
Low Voltage Directive	73/23/EEC	

### Warranty

A one year limited warranty on materials and workmanship is given with this Murphy product. Details are available on request and at [www.fwmurphy.co.uk/warranty](http://www.fwmurphy.co.uk/warranty).

## Electrical connection

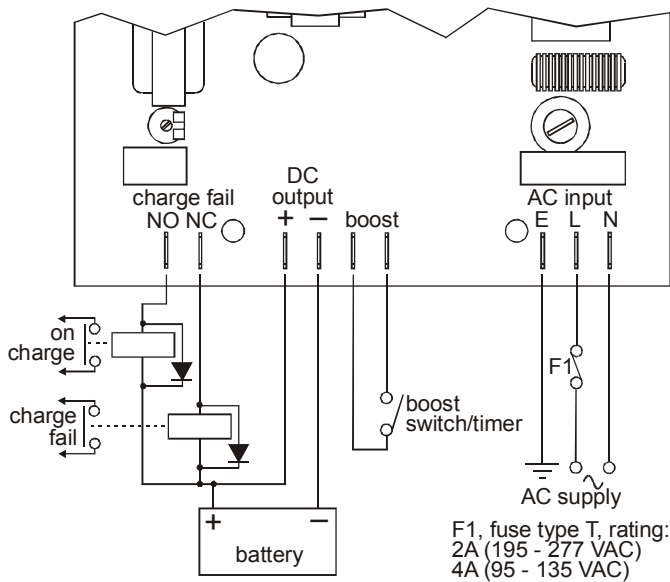

Notes:

- 1) battery output is isolated from earth
- 2) earth terminal must be connected to a low impedance earth

## Calibration

Standard calibrations:-

Battery type		float volts (VDC)	boost volts (VDC)
12V	Lead acid (6 cells)	13.6	14.1
	Ni-Cd (10 cells)	14.1	16.0
24V	Lead acid (12 cells)	27.2	28.2
	Ni-Cd (18 cells)	25.38	28.8
	Ni-Cd (20 cells)	28.2	32.0

For non-standard calibrations, please contact our engineers.

## How to order

When ordering, please specify:-

Stock Number	Description
41.70.0120	240 VAC supply, 12V lead acid, 5A
41.70.0121	240 VAC supply, 24V lead acid, 3A
41.70.0122	240 VAC supply, 10 cell NiCd, 5A
41.70.0123	240 VAC supply, 18 cell NiCd, 3A
41.70.0124	240 VAC supply, 20 cell NiCd, 3A

## Dimensions

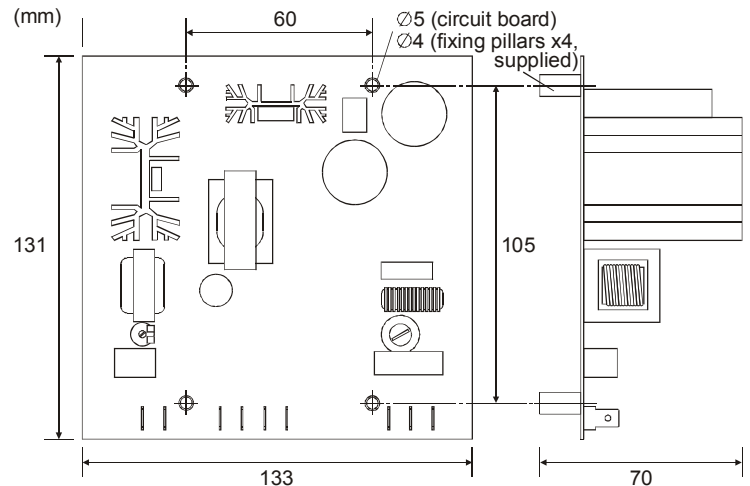

**FW Murphy**  
PO Box 470248  
Tulsa, Oklahoma 74147, USA  
tel: +1 918 317 4100  
fax: +1 918 317 4266  
email: sales@fwmurphy.com  
web: www.fwmurphy.com

**CONTROL SYSTEMS & SERVICES DIVISION**  
PO Box 1819, Rosenberg, Texas 77471, USA  
tel: +1 281 633 4500  
fax: +1 281 633 4588  
email: sales@fwmurphy.com

**MURPHY DE MEXICO S.A. DE C.V.**  
Blvd. Antonio Rocha Cordero 300, Fracción del  
Aguaje San Luis Potosí, S.L.P. México 78384  
tel: +52 444 8206264  
fax: +52 444 8206336  
**Villahermosa office tel: +52 993 3162117**  
email: ventasmex@murphymex.com.mx  
web: www.murphymex.com.mx

**INDUSTRIAL PANEL DIVISION**  
PO Box 470248  
Tulsa, Oklahoma 74147, USA  
tel: +1 918 317 4100  
fax: +1 918 317 4266  
email: sales@fwmurphy.com  
web: www.fwmurphy.com

**FRANK W. MURPHY LTD.**  
Church Rd, Laverstock, Salisbury, SP1 1QZ, UK  
tel: +44 1722 410055  
fax: +44 1722 410088  
email: sales@fwmurphy.co.uk  
web: www.fwmurphy.co.uk



*In order to consistently bring you the highest quality, full featured products, we reserve the right to change our specifications and designs at any time.*